

HEPZATO KIT contains
HEPZATO (melphalan) for Injection/
Hepatic Delivery System (HDS)

Percutaneous Hepatic Perfusion Procedure

REMS Didactic Modules Training Program
Modules 1 – 9

Document No.: MED-006
Revision: A
Effective Date: 08-Jan-2024

Delcath

HEPZATO  **KIT™**

HEPZATO  **KIT™**



HEPZATO KIT REMS

Didactic Modules Training Overview



Delcath





HEPZATO KIT Instructions For Use



Delcath Systems, Inc.'s detailed description of the clinical use of the **HEPZATO KIT** can be found in the Instructions For Use manual (IFU) and in the US Prescribing Information.

The IFU and US Prescribing Information should be thoroughly reviewed prior to training.





HEPZATO KIT REMS Didactic Modules Training Overview



This Didactic training is intended to educate the Healthcare Setting staff on the Risk Evaluation and Mitigation Strategy (REMS) and the safe and effective use of **HEPZATO(melphalan) and the HEPZATO KIT Hepatic Delivery System (HDS)**.



HEPZATO KIT is indicated as a liver-directed treatment for adult patients with uveal melanoma with unresectable hepatic metastases affecting less than 50% of the liver and no extrahepatic disease, or extrahepatic disease limited to the bone, lymph nodes, subcutaneous tissues, or lung that is amenable to resection or radiation.



HEPZATO KIT should only be utilized for percutaneous hepatic procedures (PHP) performed by qualified personnel trained in accordance with the IFU and the PI.



HEPZATO KIT REMS Didactic Modules Training Overview

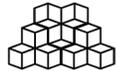

This training is comprised of nine Didactic Modules



Training requirements are established for each specialist role of the PHP Procedure team



All PHP Procedure team members are required to complete the didactic module that provides an overview for their role in the procedure

Module #	Module	IR	Anesthesiologist	Perfusionist
1	REMS Program Details and Requirements	Required	Required	Required
2	HEPZATO Overview	Required	Required	Required
3	Treatment Planning	Required	Required	Required
4	Perfusion Circuit	Optional	Required	Required
5	Drug Preparation & Injection	Optional	Optional	Required
6	Procedure Day	Required	Required	Required
7	Catheterization & Drug Infusion	Required	Optional	Required
8	Hemodynamics Management	Optional	Required	Optional
9	Post Procedure	Optional	Required	Optional

The Oncologist and other staff members may also complete Didactic Module training but are not required to complete this training.



HEPZATO KIT Clinical Treatment Team

HEPZATO KIT Clinical Treatment Team

PHP PROCEDURE TEAM (REQUIRES REMS TRAINING)

- Interventional Radiologist (IR)**
IR or Surgical Oncologist must be the LEADER during the procedure and communication is paramount
- Anesthesiologist (AN)**
- Perfusionist (PF)**

OTHER HEPZATO KIT CLINICAL TREATMENT TEAM MEMBERS (DO NOT REQUIRE REMS TRAINING)

- Oncologist** (*Medical and/or Surgical; SO/MO*)
 - Must commit to managing the patient before and after the procedure
 - May be involved during the procedure
- Pharmacist**
- Registered Nurse (RN)**
- Interventional Radiology Staff**
- Intensivist or Critical Care Specialist**
Manages patient immediately post-procedure along with the SO/MO

Each health care professional must communicate and collaborate to ensure that each of the individual procedures are appropriately timed.



MODULE 1

Risk Evaluation & Mitigation Strategy (REMS) *Program Details and Requirements*

HEPZATO KIT REMS Didactic Modules Training

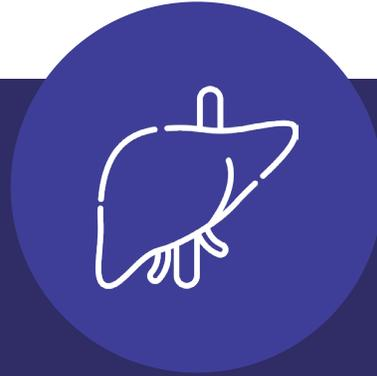

This educational didactic module contains information on serious adverse events associated with the use of HEPZATO KIT, including the risks of severe peri-procedural complications including hemorrhage, hepatocellular injury, and thromboembolic events. This is not a comprehensive list of adverse events associated with HEPZATO KIT.

Please refer to the prescribing information for a comprehensive list of adverse events.



HEPZATO Indication

HEPZATO is indicated as a liver-directed treatment for adult patients with uveal melanoma with unresectable hepatic metastases affecting less than 50% of the liver and no extrahepatic disease, or extrahepatic disease limited to the bone, lymph nodes, subcutaneous tissues, or lung that is amenable to resection or radiation.

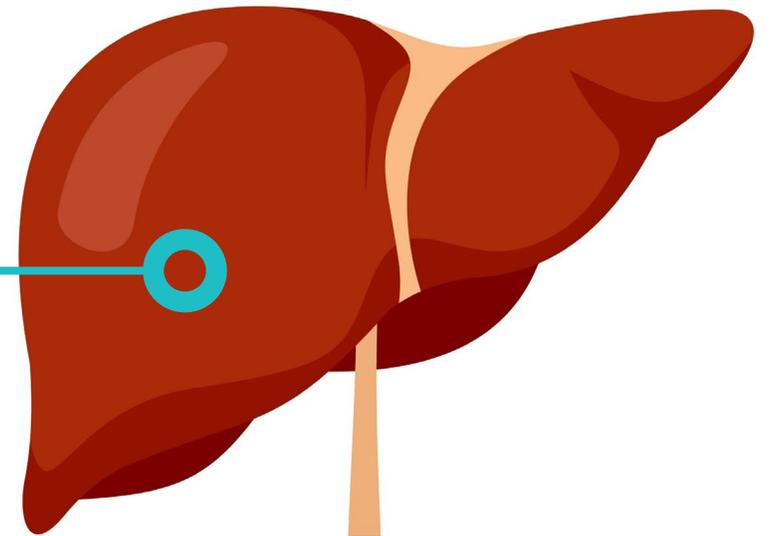



What is a REMS?



A Risk Evaluation and Mitigation Strategy (REMS) is a program required by the FDA to manage known or potential serious risks associated with a drug product. The FDA has determined that a REMS is necessary to ensure that the benefits of HEPZATO KIT outweigh its risks.



The goal of the HEPZATO KIT REMS is to mitigate the risks of severe peri-procedural complications including hemorrhage, hepatocellular injury, and thromboembolic events associated with HEPZATO KIT.



HEPZATO KIT REMS Summary



**HEPZATO KIT
is only available
through the
HEPZATO KIT
REMS**



**Healthcare settings
that dispense
HEPZATO KIT must
be certified in the
REMS**



**PHP procedure
team members that
perform procedures
with HEPZATO KIT
must be trained**

HEPZATO KIT Clinical Treatment Team

PHP Procedure Team



Interventional Radiologist



Anesthesiologist



Perfusionist



Certified Healthcare Setting

HEPZATO KIT Clinical Treatment Team - Others



Oncologist



Pharmacist



Chemotherapy HCP



Intensivist



Percutaneous Hepatic Perfusion (PHP) Procedure Team

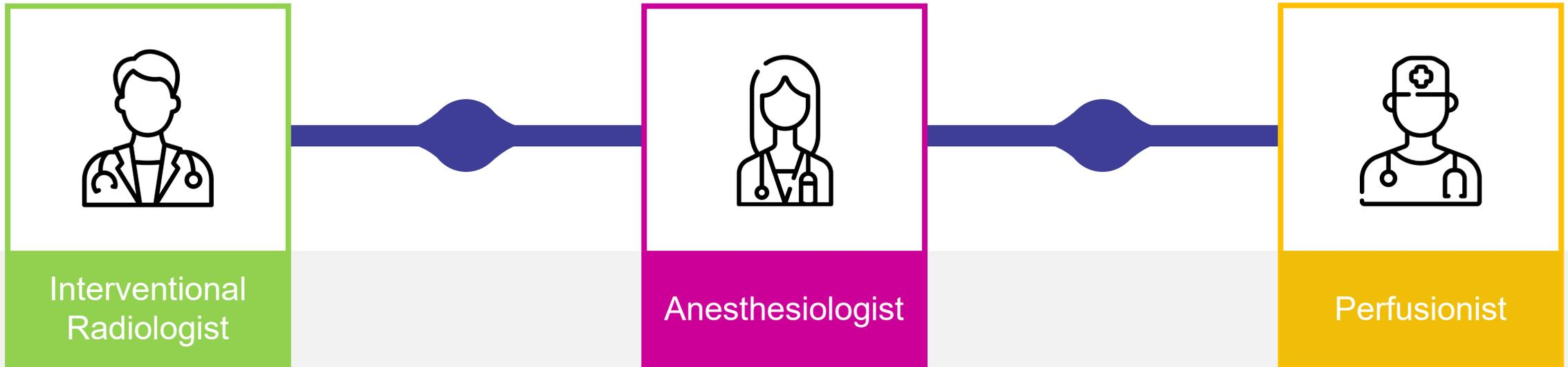

The percutaneous hepatic perfusion procedure team(s) must include healthcare providers with expertise in interventional radiology, anesthesiology, and perfusion in accordance with the Instructions for Use.



Healthcare Setting Certification Requirements

As a condition of certification, the Healthcare Setting must:



Have a percutaneous hepatic perfusion procedure team(s) **that must include** healthcare providers with expertise in interventional radiology, anesthesiology, and perfusion as described in the Instructions for Use.



Have the following on-site: interventional radiology suite or operating room with fluoroscopy and with resuscitation personnel, equipment, and medications





Authorized Representative Requirements

 The Healthcare Setting must designate an **Authorized Representative (AR)** to carry out the certification process and oversee implementation and compliance with the REMS requirements on behalf of the healthcare setting.

To become certified, the Authorized Representative must:



Carry out the certification process and oversee implementation and compliance with the REMS requirements on behalf of the healthcare setting.



Review HEPZATO KIT REMS Prescribing Information, Instructions for Use, **Program Overview**, and this **Didactic Modules**



Enroll in the REMS Program by completing and submitting the **Healthcare Setting Enrollment Form** to the REMS



Establish processes and procedures to ensure new members of the PHP procedure team are trained and successfully complete the Proctorship training and complete and submit the **Criteria for Procedural Competency Checklist** to the REMS.



Who Can Be an Authorized Representative?

An Authorized Representative at the Healthcare Setting can be a:

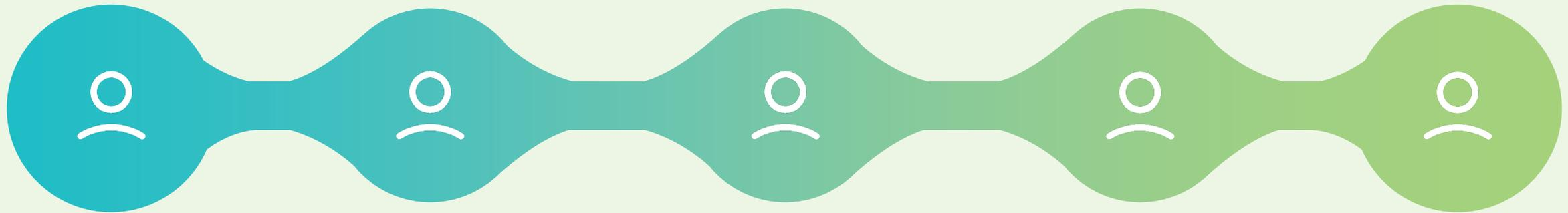

Physician



Nurse



Pharmacist



Administrator



Any responsible individual assigned by the Healthcare Setting



Percutaneous Hepatic Perfusion (PHP) Team Requirements

The PHP Procedural Team will be required to:



Review the **HEPZATO** Prescribing Information and **HEPZATO KIT** Instructions for Use



Review the **Program Overview**, this **Didactic Module** and undergo the Preceptorship Training provided by Delcath Systems, Inc.

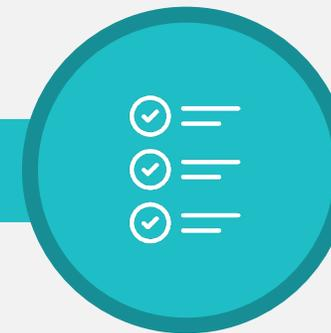

Successfully complete the Proctorship and **Criteria for Procedural Competency Checklist**



Before HEPZATO KIT Administration

Before administering HEPZATO KIT,
the Healthcare Setting must:

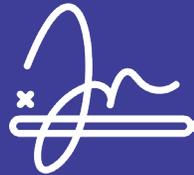

Obtain an authorization to dispense
by contacting the REMS Coordinating
Center to verify the PHP Procedure
Team is qualified using the **Procedure
Team Qualification Form**





During HEPZATO KIT Administration

During and for a minimum of 72 hours after the PHP procedure, the Healthcare Setting must:



Assess the patient for severe peri-procedural complications associated with HEPZATO KIT.

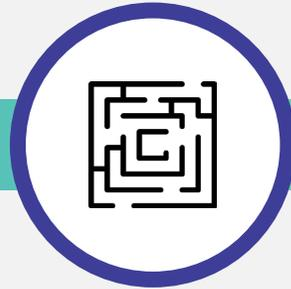

Document severe peri-procedural complications using the **Severe Peri-Procedure-related Complications Adverse Events Documentation Form** and submit to the REMS.



Follow up may be virtual or via telephone in patients discharged prior to 72 hours



Maintain Healthcare Setting Certification

To maintain the ability to dispense the HEPZATO KIT, a Healthcare Setting must:



Have a PHP procedure team(s) that must include healthcare providers with expertise in interventional radiology, anesthesiology, and perfusion



Have PHP team members who have each performed one PHP procedure in the first six months following completion of training, a second procedure in the next six months, and at least two procedures annually thereafter



Have the following on-site: interventional radiology suite or operating room with fluoroscopy and with resuscitation personnel, equipment, and medications



Have a new Authorized Representative enroll in the REMS by completing the **Healthcare Setting Enrollment Form** and submitting it to the REMS



Healthcare Setting Responsibilities

At all times, the Healthcare Setting must:



Maintain records of each PHP team members training



Maintain records of the PHP procedures performed with HEPZATO KIT and the associated PHP procedure team members' participation



Maintain records that indicate the processes and procedures are in place and being followed



Comply with audits carried out by Delcath Systems, Inc., or a third party acting on behalf of Delcath Systems, Inc., to ensure that all REMS specific processes and procedures are in place and being followed



HEPZATO KIT REMS Materials Summary

Program Overview	<ul style="list-style-type: none">• Reviewed by the Authorized Representative and the PHP procedure team members• Educates on the key risks, management of the risks, and REMS requirements
Didactic Modules	<ul style="list-style-type: none">• Reviewed by the Authorized Representative and the PHP procedure team members• Educates on the key risks, management of the risks, and REMS requirements
Healthcare Setting Enrollment Form	<ul style="list-style-type: none">• Completed and submitted by a designated Authorized Representative• Agreement to comply with the REMS requirements
Criteria for Procedural Competency Checklist	<ul style="list-style-type: none">• Completed by the PHP procedure team members as part of the Proctorship• Retained on-site as documentation of training and submitted to the REMS
Procedure Team Qualification Status Form	<ul style="list-style-type: none">• Completed and submitted by the Authorized Representative and/or Healthcare Setting staff to obtain authorization to dispense each HEPZATO KIT to verify the PHP procedure team is qualified
Severe Peri-Procedure-Related Complications Adverse Events Documentation Form	<ul style="list-style-type: none">• Completed and submitted by the Healthcare Setting to report any severe peri-procedural complications associated with HEPZATO KIT during and after administration for at least 72 hours
REMS Program Website	<ul style="list-style-type: none">• Dedicated resource for REMS information

HEPZATO KIT Procedural Overview



Interventional
Radiologist



Anesthesiologist



Perfusionist



HEPZATO KIT

HEPZATO KIT is a closed circuit of catheters and filters utilized to deliver a chemotherapeutic agent (melphalan) directly with simultaneous filtration of hepatic venous blood during drug infusion and washout, which results in loco-regional delivery of a relatively high melphalan dose but also reduced systemic exposure.

There are risks including peri-procedural complications that may be severe and or life threatening

The prominent risks include hemorrhage, hepatocellular injury, and thromboembolic events

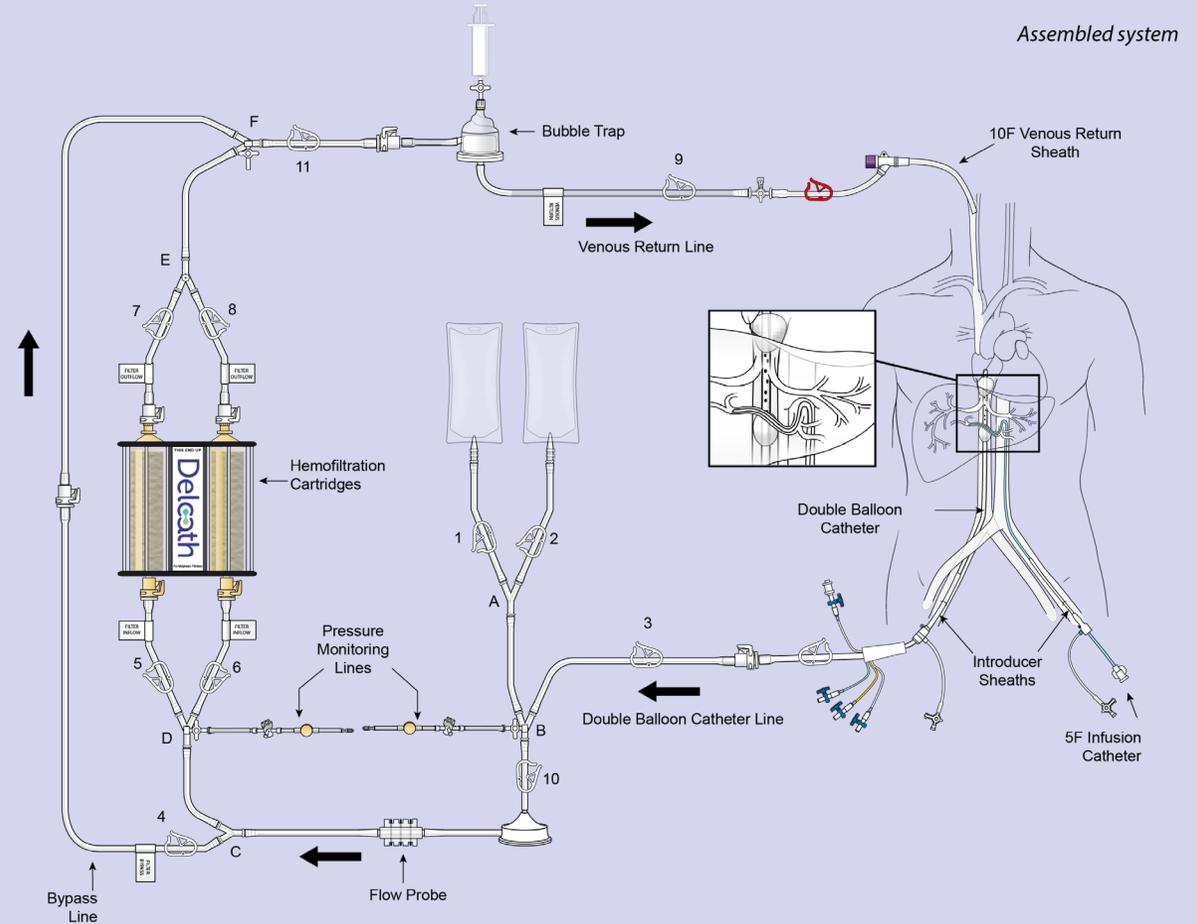



Severe Peri-Procedural Complications

Hemorrhage, hepatocellular injury, and thromboembolic events have been observed when HEPZATO has been administered via hepatic intra-arterial administration.



Administration of HEPZATO requires general anesthesia and extracorporeal bypass of circulation which may cause life threatening or fatal adverse effects



Ensure the patient is euvolemic but do not overhydrate the patient.



Monitor for these peri-procedural complications during the procedure and for at least 72 hours following the procedure.



Contraindications

HEPZATO KIT is contraindicated in patients with:

Active intracranial metastases or brain lesions with a propensity to bleed

Liver failure, portal hypertension, or known varices at risk for bleeding

Surgery or medical treatment of the liver in the previous 4 weeks

Active cardiac conditions including, but not limited to, unstable coronary syndromes (unstable or severe angina or myocardial infarction), worsening or new-onset congestive heart failure, significant arrhythmias, or severe valvular disease

History of allergies or known hypersensitivity to melphalan or a component or material utilized within the HEPZATO KIT including natural rubber latex, heparin, and severe hypersensitivity to iodinated contrast not controlled by antihistamines and steroids



Warnings and Precautions (1)

Hemorrhage, hepatocellular injury, and thromboembolic events have been observed when melphalan has been administered via hepatic intra-arterial administration of HEPZATO. Administration of HEPZATO requires general anesthesia and extracorporeal bypass of circulation which may cause life threatening or fatal adverse effects. Ensure the patient is euvolemic but do not overhydrate the patient. Monitor for these peri-procedural complications during the procedure and for at least 72 hours following the procedure.

To mitigate the risk of thromboembolic events, administer anticoagulation as described in the IFU during the procedure.



Warnings and Precautions (2)

Due to the risk of bleeding, do not use in patients with uncorrectable coagulopathies and delay treatment with the HEPZATO KIT for at least 4 weeks after surgery or other medical procedure involving the liver. Platelets and clotting factors may be removed during the HEPZATO KIT procedure. Monitor platelets and coagulation parameters as described in the IFU. If life-threatening bleeding occurs during the procedure, reverse anticoagulation as described in the IFU and correct coagulopathy as appropriate. Discontinue anticoagulation with warfarin or other oral anticoagulants prior to the procedure until hemostasis has been restored after the procedure and no bleeding complications have been observed. Refer to the Prescribing Information of the anticoagulant agent for bridging recommendations for anti-coagulation prior to surgical procedures. Discontinue drugs affecting platelet function such as aspirin, non-steroidal anti-inflammatory drugs, or other anti-platelet drugs one week before the procedure.



Warnings and Precautions (3)

Patients with abnormal hepatic vascular (especially arterial supply) or biliary (especially re-implantation of bile duct) anatomy or gastric acid hypersecretion syndromes may be at increased risk of peri-procedural complications or other severe adverse reactions. Screen patients for a history of prior surgeries involving the bile duct to assess whether the patient is an appropriate candidate for HEPZATO KIT and monitor patients for adverse reactions following HEPZATO KIT administration.

Procedure-related reductions in blood pressure including severe hypotension can occur during the HEPZATO KIT procedure. Closely monitor blood pressure during the procedure. Patients may require fluid support and vasopressors. To reduce the risk of severe hypotension, temporarily discontinue ACE-inhibitors, calcium channel blockers, or alpha-1-adrenergic blockers for at least 5 half-lives prior to treatment with the HEPZATO KIT. If necessary, use other short-acting antihypertensive drugs to manage blood pressure during the peri-procedure period.



Warnings and Precautions (4)

Hematologic adverse reactions, including thrombocytopenia, anemia, and neutropenia have been reported in patients treated with HEPZATO. The risk of hematologic adverse reactions may be increased in patients who have received prior chemotherapy, bone irradiation, or who have compromised bone marrow function.

Monitor patients for severe infections, bleeding, and symptomatic anemia. Only administer HEPZATO in patients with platelets $>100,000$ /microliter, hemoglobin ≥ 10.0 gm/dL and neutrophils $>2,000$ /microliter. Administer transfusions or growth factors as appropriate



Warnings and Precautions (5)

Hypersensitivity reactions, including anaphylaxis, have occurred in approximately 2% of patients who received an intravenous (IV) formulation of melphalan. These reactions with melphalan are characterized by urticaria, pruritus, edema, skin rashes, and in some patients, tachycardia, bronchospasm, dyspnea, and hypotension. Hypersensitivity can occur in patients with or without prior exposure to IV or oral melphalan.

When a hypersensitivity reaction is observed, immediately terminate the hepatic arterial HEPZATO infusion and administer necessary supportive care.

Patients with a history of allergic reactions to iodinated contrast may experience hypersensitivity reactions, including anaphylaxis, during treatment with the HEPZATO KIT. Premedicate patients with a history of allergic reaction to iodinated contrast prior to treatment with HEPZATO KIT. Do not administer HEPZATO KIT in patients with a history of severe allergic reactions or anaphylaxis to iodinated contrast.



Warnings and Precautions (6)

Gastrointestinal adverse reactions including nausea and vomiting, abdominal pain, and diarrhea are common, and occurred in 84% of patients treated with HEPZATO in the FOCUS trial. Administer a proton-pump inhibitor the day prior to and the morning of the procedure. If anti-emetic treatment is required, pre-medicate with anti-emetic therapy in subsequent cycles.

Melphalan has been shown to cause chromatid or chromosome damage in humans. Secondary malignancies, including acute nonlymphocytic leukemia, myeloproliferative syndrome, and carcinoma, have been reported in patients with cancer treated with intravenous alkylating drugs including melphalan. Some patients also received other chemotherapeutic agents or radiation therapy. Precise quantification of the risk of acute leukemia, myeloproliferative syndrome, or carcinoma is not possible. Published reports of leukemia in patients who have received oral or IV melphalan (and other alkylating drugs) suggest that the risk of leukemogenesis increases with chronicity of treatment and with cumulative dose.



Warnings and Precautions (7)

Based on animal studies and its mechanism of action, melphalan can cause fetal harm when administered to a pregnant woman. Melphalan is genotoxic, targets actively dividing cells, and was embryolethal and teratogenic in rats. Advise pregnant women of the potential risk to a fetus. Advise females of reproductive potential to use effective contraception during treatment with HEPZATO and for 6 months after the last dose. Advise males with female partners of reproductive potential to use effective contraception during treatment with HEPZATO and for 3 months after the last dose.

Melphalan-based chemotherapy regimens have been reported to cause suppression of ovarian function in premenopausal women, resulting in persistent amenorrhea in approximately 9% of patients. Reversible or irreversible testicular suppression has also been reported.



Adverse Events and Complications

In the multicenter, open label pivotal study, [FOCUS (NCT02678572)], serious adverse reactions occurred in 45% of patients who received HEPZATO.

Serious adverse reactions occurring in $\geq 2\%$ of patients were thrombocytopenia (10%), neutropenia (8%), febrile neutropenia (7%), platelet count decreased (6%), leukopenia (4.2%), cardiac arrest (3.2%), neutrophil count decreased (2.1%), hypoxia (2.1%), pleural effusion (2.1%), pulmonary edema (2.1%), and deep vein thrombosis (2.1%).

Fatal adverse reactions occurred in 3 (3.2%) patients who were treated with HEPZATO; these included cardiac arrest, acute hepatic failure and bacterial peritonitis.



Adverse Event Reporting



Reporting of serious adverse events after administration of HEPZATO KIT is vital for the continued monitoring of the risk/benefit balance of the use of HEPZATO KIT



Healthcare providers must report severe peri-procedural complications including adverse events of hemorrhage, hepatocellular injury, and thromboembolic events using the **Severe Peri-Procedure-related Complications Adverse Events Documentation Form** to Delcath Systems, Inc. via e-mail at coordinator@HEPZATOKITREMS.com



Healthcare providers **are encouraged to report** other adverse **reactions** to Delcath at 1-833-632-0458 or to the FDA at 1-800-FDA-1088 or www.fda.gov/medwatch

HEPZATO KIT REMS Information

For further information, please visit
www.HEPZATOKITREMS.com or call 1-833-632-0457

MODULE 2

HEPZATO KIT Overview



Interventional
Radiologist



Anesthesiologist



Perfusionist



MODULE 2

Purpose and Objectives

The introductory module provides a general overview of **HEPZATO KIT** and PHP procedure including target patient population and indication, contraindications, general safety and precautions, and clinical efficacy/safety information. Training will prepare HCPs for individual education modules based on specialized role.



Understand the mechanism of action of melphalan and the HDS and how these components work as a system.



Understand melphalan clinical pharmacology, the pharmacokinetic profile, and how the system limits melphalan systemic exposure.



Review target patient population and indications, contraindications, precautions, and special populations.



Understand the safety and adverse events profile for HEPZATO KIT and methods to mitigate adverse events.



PHP Procedure with HEPZATO KIT

HEPZATO KIT is a drug/device combination product and is indicated as a liver-directed treatment for adult patients with uveal melanoma with unresectable hepatic metastases affecting less than 50% of the liver with no extrahepatic disease, or extrahepatic disease limited to the bone, lymph nodes, subcutaneous tissues, or lung that is amendable to resection or radiation.

The PHP Procedure with HEPZATO KIT is based on **3 principles**



Isolation of the liver circulation through the occlusion of the inferior vena cava caudal and cranial of the hepatic veins.

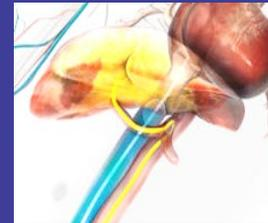

Infusion of high dose melphalan directly into the liver to **saturate** hepatic parenchyma and residing cancer cells.



Filtration of the hepatic circulation to limit melphalan concentration before returning the blood to the systemic circulation thereby reducing melphalan systemic exposure.





HEPZATO KIT System Components

HEPZATO KIT consists of a closed circuit of catheters and drug specific filters utilized to deliver a chemotherapeutic agent (melphalan) to the hepatic artery and to lower the concentration of the agent in the blood before it is returned to systemic circulation.

HEPZATO KIT Shelf Box



(5x5) Melphalan Drug Pack



Secondary Diluent



Drug KIT



HDS KIT

- Double Balloon Catheter (DBC)
- Extracorporeal Circuit including Filter

- Sheaths and Obturators
- Multiple other smaller components



Supplied Disposable Components

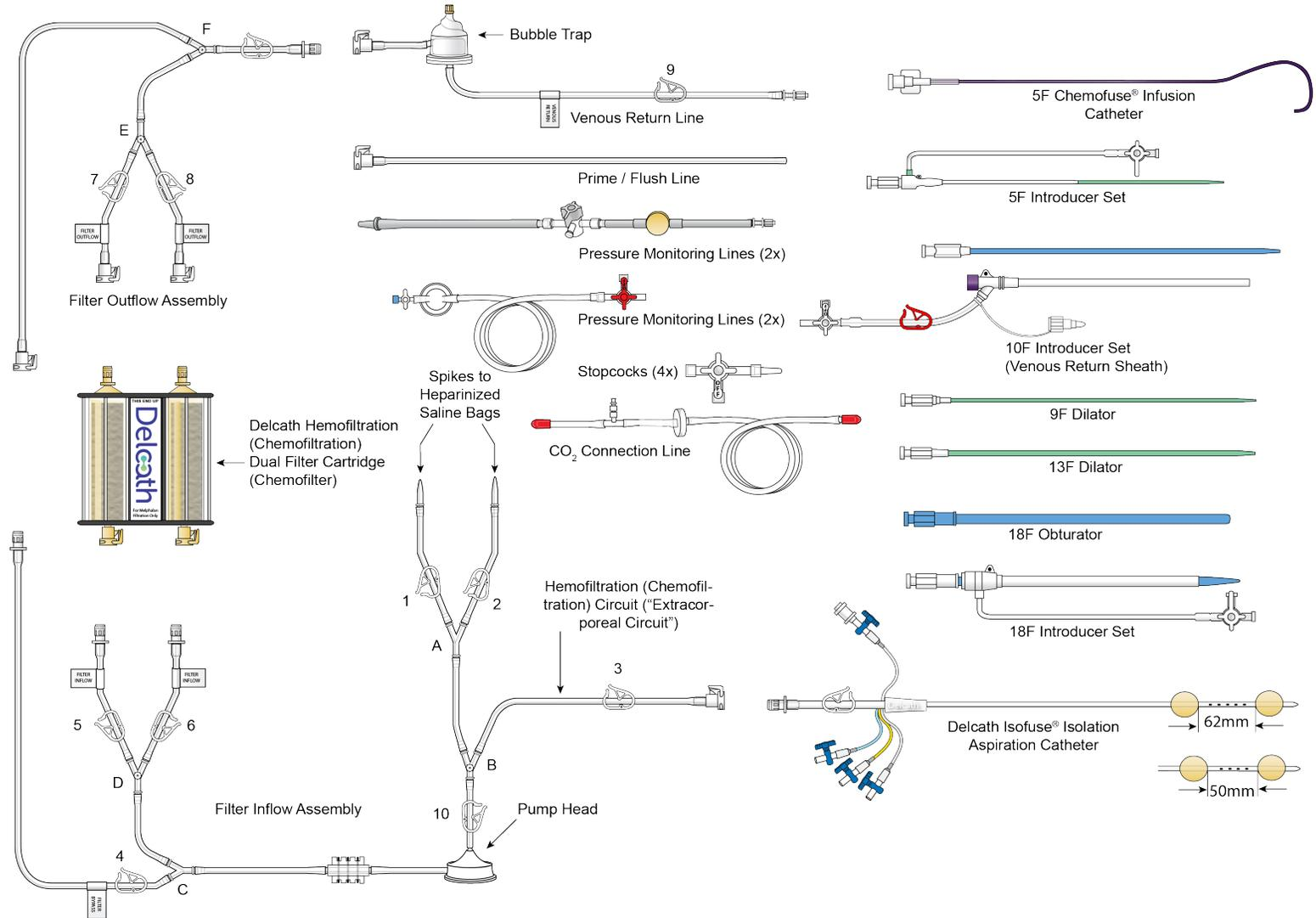



Assembled System

See IFU for full system description

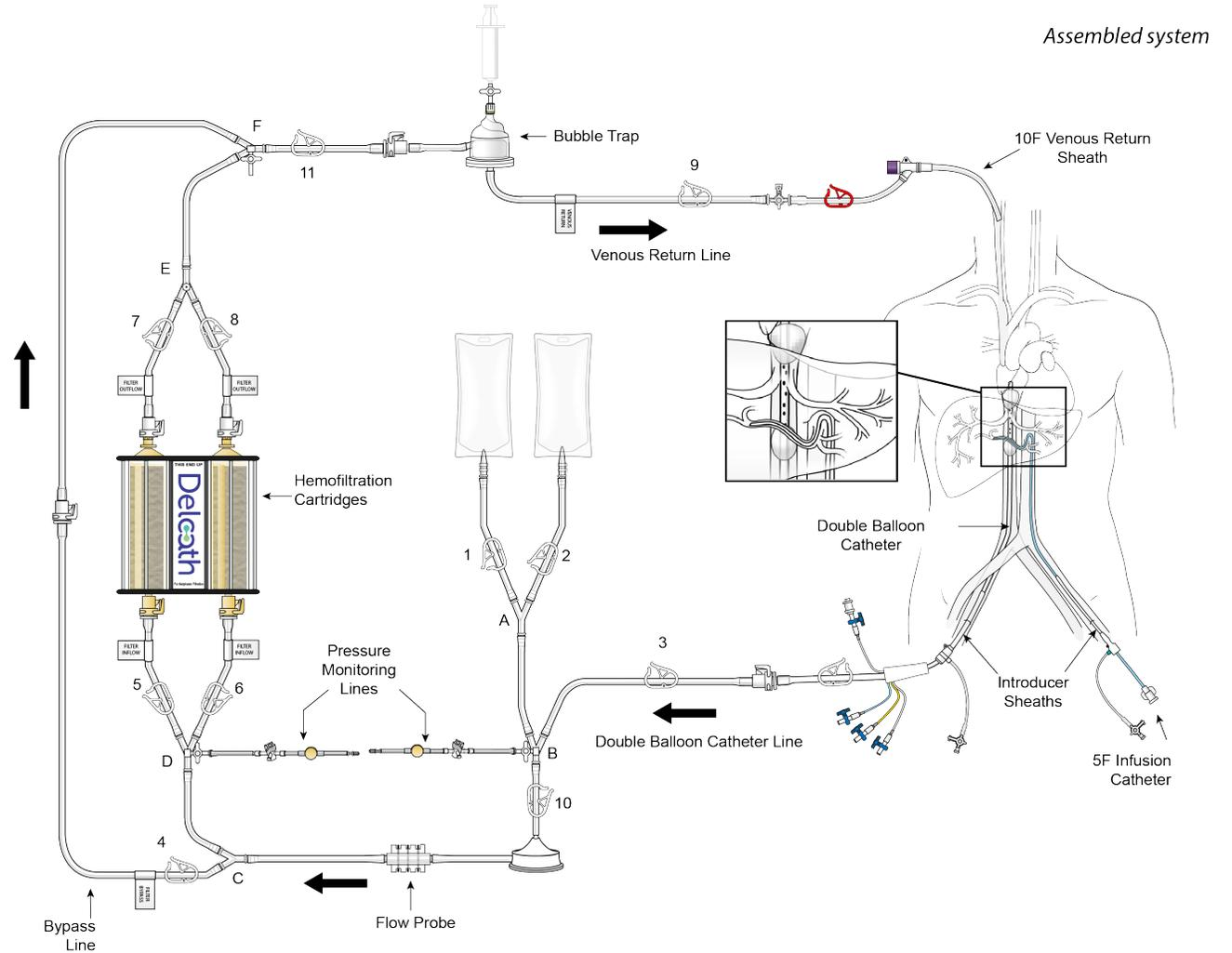

Assembled system

Additional Items needed *(not included)*

- **Bubble Trap holder**
- **Medtronic Bio-Console 560 Speed Controller System (“Pump”)**
- **Medtronic Bio-Probe TX50P (“Flow Transducer”)**
- **CO₂ Supply for Priming Dual Filter**
- **Drug Delivery Disposables:**
 - One (1) Medrad 150mL Syringe (Polypropylene (PP)-Barrel & Polyisoprene-Plunger) or equivalent
 - Two (2) Intravenous Administration Set with spike & drip chamber (Polyvinylchloride (PVC)-tubing, Acrylonitrile butadiene styrene (ABS) & Polyethylene (PE)-Drip Chamber & Polycarbonate (PC)-Luer) or equivalent
 - One (1) - 48” injector lines (PVC-Tubing & PC-Luer) or equivalent
 - Five (5) 3-way stopcocks (PC-body, High Density Polyethylene (HDPE) or Acetal-Handles) or equivalent
 - Three (3) 20 mL syringes (PP-Barrel & Polyisoprene-Plunger) or equivalent
- **Microcatheters (Maximal Distal End OD = 2.8F) – for Selective Drug Infusion (at Interventional Radiologist discretion). Select one from Delcath qualified microcatheters listed below:**
 - Merit Maestro (Merit Medical Systems, Inc., So. Jordan, UT, USA)
 - BSC Renegade Hi-Flo (Boston-Scientific Corp.; Natick, MA, USA)
 - Terumo Progreat (Terumo Medical Corp., Somerset, NJ, USA)



Healthcare Setting Requirements



The procedure must be performed in an appropriately equipped interventional radiology suite with fluoroscopy or an operating room designed and equipped similarly.

Resuscitation personnel, equipment, and medication must be immediately available.



HEPZATO KIT Clinical Treatment Team

PHP Procedure Team



Interventional Radiologist



Anesthesiologist



Perfusionist



Certified Healthcare Setting

HEPZATO KIT Clinical Treatment Team - Others



Oncologist



Pharmacist



Chemotherapy HCP



Intensivist



PHP Procedure with HEPZATO KIT

ISOLATION

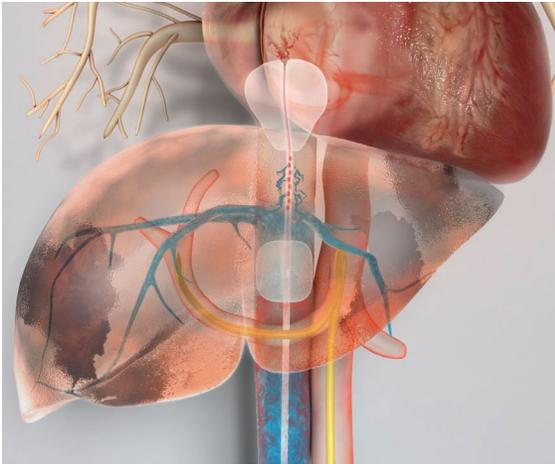

Isolates hepatic blood flow

SATURATION

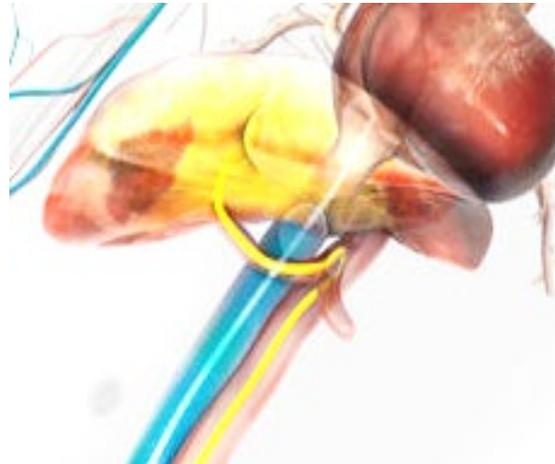

A high dose of HEPZATO is delivered to the liver

FILTRATION

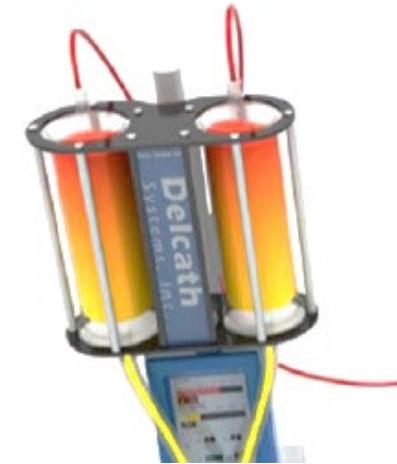

Venous blood from the liver is filtered to reduce melphalan concentration prior to returning the blood to systemic circulation



PHP Procedure with HEPZATO KIT

Isolation



The double balloon catheter allows for the isolation of the hepatic venous blood.

Hepatic venous blood flow isolation allows melphalan to be concentrated within the liver.

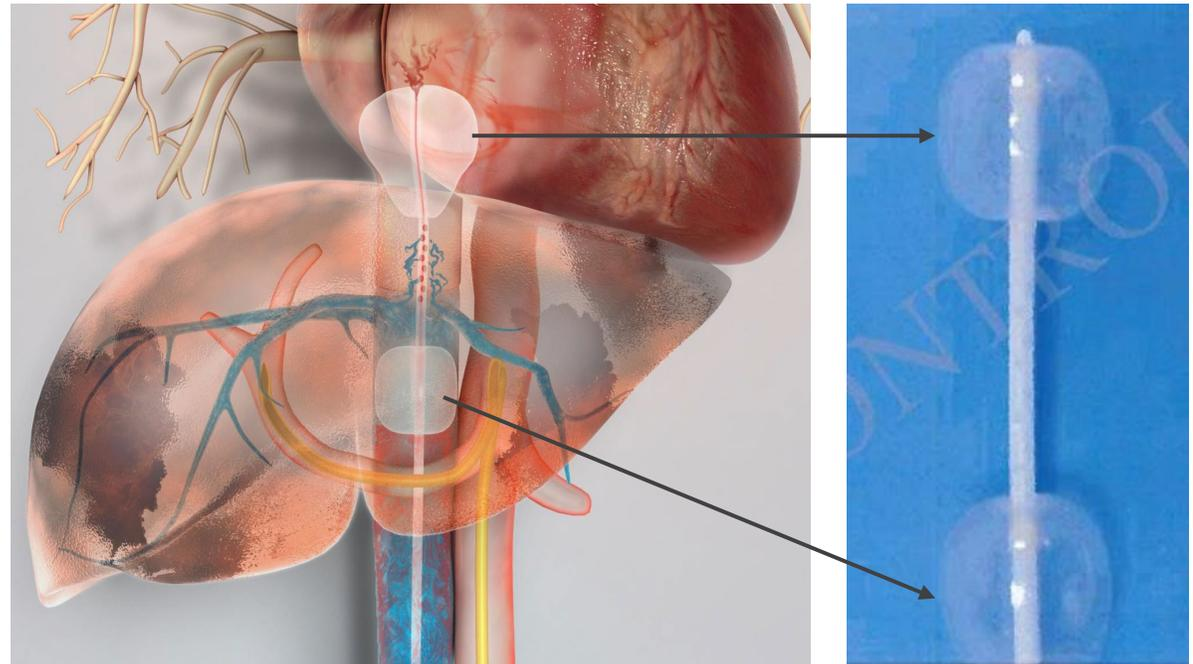

Double Balloon Catheter



PHP Procedure with HEPZATO KIT

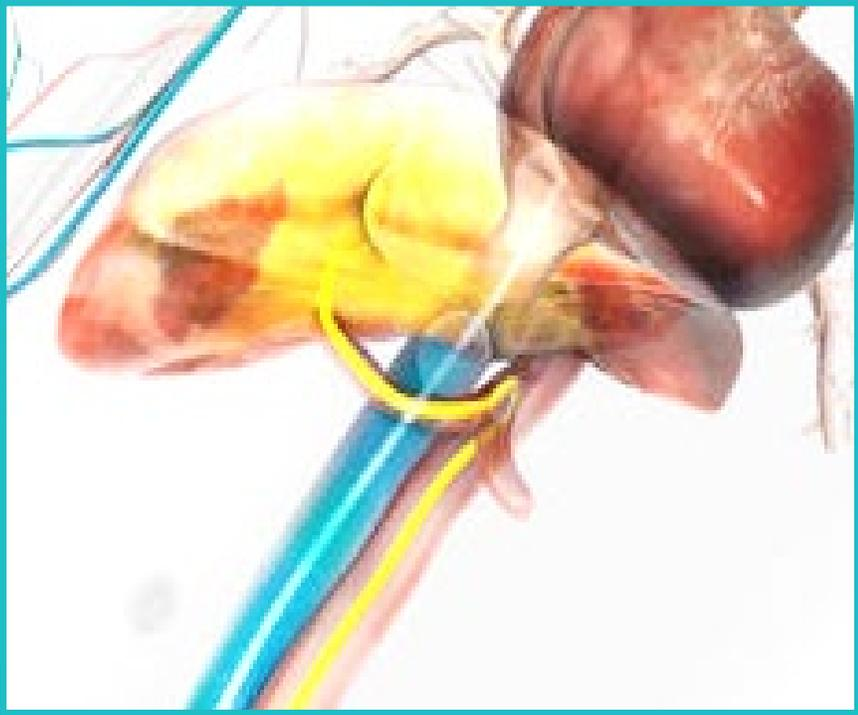

Saturation

Saturation involves a high concentration of melphalan delivery to the liver through the hepatic artery.



HEPZATO (melphalan)

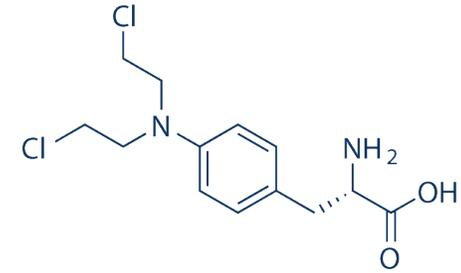

It is used as a chemotherapy.

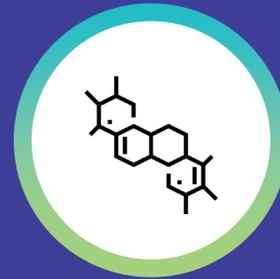

It is also known as L-PAM or L-phenylalanine.



It is a bifunctional alkylating drug.

Vahrmeijer AL, van Dierendonck JH, Keizer HJ, Beijnen JH, Tollenaar RA, Pijl ME, et al. Increased local cytostatic drug exposure by isolated hepatic perfusion: a phase I clinical and pharmacologic evaluation of treatment with high dose melphalan in patients with colorectal cancer confined to the liver. *Br J Cancer*. 2000;82(9):1539–46.



PHP Procedure with HEPZATO KIT

Filtration



- The extracorporeal bypass circuit reduces systemic melphalan exposure by ~90%.
- The majority of melphalan does not reach the systemic circulation due to the extracorporeal filtration procedure.

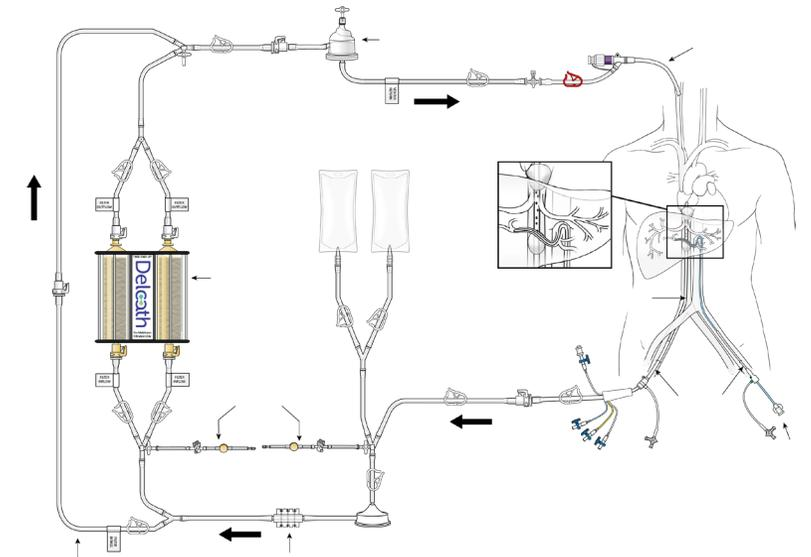
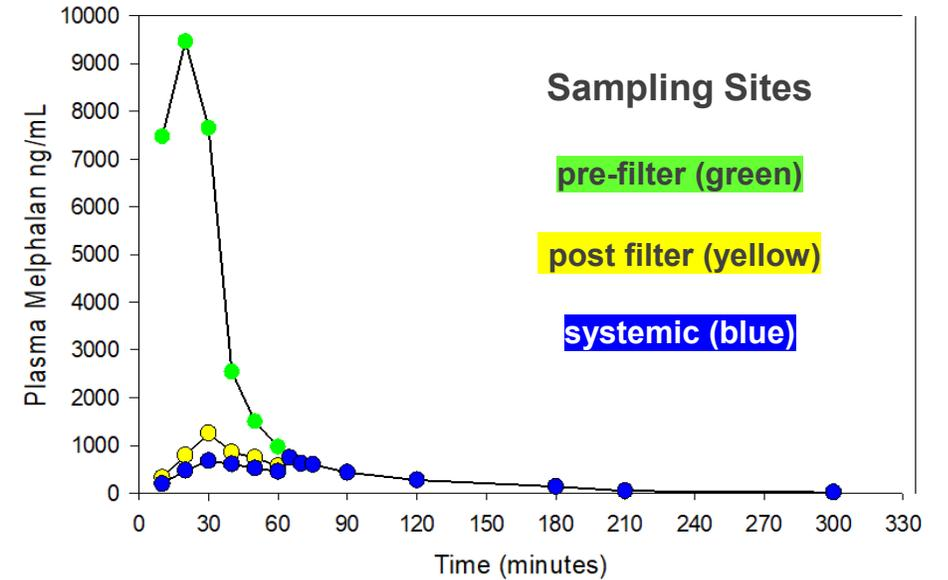

HEPZATO KIT Clinical Treatment Team

PHP Procedure Team



Interventional Radiologist



Anesthesiologist



Perfusionist



Certified Healthcare Setting

HEPZATO KIT Clinical Treatment Team - Others



Oncologist



Pharmacist



Chemotherapy HCP



Intensivist



HEPZATO KIT Clinical Treatment Team

Oncologist (Medical Oncologist)



Experience

Manage (metastatic) uveal melanoma patients

Monitor and manage chemotherapy toxicities



Communicates

Overall treatment plan and referrals



Responsibilities

Refer patient for PHP treatment

Complete medical management of the patient pre- and post-operative care



Coordinates with

Interventional Radiologist, Surgical Oncologist, Anesthesiologist, and other HCPs



HEPZATO KIT Clinical Treatment Team

Oncologist (Surgical Oncologist)



Surgical
Oncologist



Experience

Monitor and manage chemotherapy toxicities



Communicates

HEPZATO use and risks
HEPZATO KIT procedural risks



Responsibilities

May share leadership of procedure with the Interventional Radiologist
Complete medical management of the patient pre- and post-operative care



Coordinates with

Medical Oncologist, Perfusionist, Surgical Oncologist, Anaesthesiologist, and other HCPs



HEPZATO KIT Clinical Treatment Team



Oncologist



Pre-Procedure

- Indications, contraindications, warnings and precautions
- Clinical data summary: Efficacy and safety
- Patient screening and eligibility
- Pre-procedure exam and prescribing pre procedure medications



Procedure

- Procedural related complications
- HEPZATO dosing, preparation and delivery



Post-Procedure

- Mitigating and managing HEPZATO related adverse effects
- Preparing patient for next treatment cycle



HEPZATO KIT PHP Procedure Team

Interventional Radiologist



Interventional Radiologist



Experience

Advanced experience in vascular procedures and liver directed therapies



Communicates

Procedural directives
Vascular anatomy and access
Double balloon inflation



Responsibilities

Leads the procedure
Assess vascular anatomy
Access vasculature using sheaths & catheters
Inflate and deflate double balloons



Coordinates with

Perfusionist, Medical/Surgical Oncologist, Anaesthesiologist, and other HCPs



HEPZATO KIT PHP Procedure Team



Interventional
Radiologist



Pre-Procedure

- Indications, contraindications, warnings and precautions
- Clinical data summary: Efficacy and safety
- Patient screening and eligibility
- Identify HEPZATO infusion location based on disease burden and hepatic artery anatomy to ensure adequate drug infusion to the entire liver.
- Pre procedure exam and prescribing pre procedure medications



Procedure

- HEPZATO KIT components and non-KIT required accessories
- HEPZATO dosing, preparation and delivery
- Vascular access sites and catheterization
- Hepatic artery mapping and embolization when needed
- Placing hepatic artery infusion catheter
- Ordering and receiving HEPZATO



HEPZATO KIT PHP Procedure Team



Interventional
Radiologist



Procedure (*cont.*)

- Introducing and positioning the double balloon catheter (DBC). Technique for balloon expansion, catheter re-position, techniques for assessing and maintaining occlusion, troubleshooting, managing intra-procedural complications and catheter withdrawal.
- Connecting extracorporeal circuit to patient
- Expanding balloons
- Administering HEPZATO
- Monitoring for hepatic artery patency and/or spasm and methods to relieve spasm.
- Procedural related complications



Post-Procedure

- Collapsing balloon, disconnecting from extracorporeal circuit and withdrawing catheters
- Remove sheaths and close access sites
- Monitor for bleeding



HEPZATO KIT PHP Procedure Team

Anesthesiologist



Anesthesiologist



Experience

Administration and monitoring of general anesthesia

Respiratory and cardiovascular surgical intervention and support



Communicates

Cardiac status – mean arterial pressure, blood pressure

Vasopressor administration

Respiratory status

Post procedure protocol



Responsibilities

Management of sedation, analgesia, respiratory and blood pressure/ cardiovascular support

Fluid administration and management

Post procedure management



Coordinates with

Surgical Oncologist, Interventional Radiologist and Perfusionist, Intensivist



HEPZATO KIT PHP Procedure Team



Anesthesiologist



Pre-Procedure

- Patient assessment and eligibility for general anesthesia and mechanical ventilation
- Patient screening for cardiac disease including coronary insufficiency, valvular heart disease and left ventricular systolic and diastolic dysfunction



Procedure

- Hemodynamic preparation and monitoring
- Fluid preparation and management
- Anticoagulation preparation and management
- Vasopressor preparation and management
- Preparing for Double Balloon Catheter balloon expansion in the IVC
- Preparing for filters going “online”
- Monitoring and managing extracorporeal filtration system



Post-Procedure

- Reverse coagulopathy
- Monitor and manage hemodynamics
- Maintain and support airway



HEPZATO KIT PHP Procedure Team

Perfusionist



Perfusionist



Experience

Extracorporeal circuit assembly and management



Communicates

When the circuit is assembled
When circuit lines are open and closed
Activated clotting time
Pump flow and pressures



Responsibilities

Verify KIT type based on IR order
Checks for KIT expiration date
Opens HEPZATO KIT
Records KIT parts serial number before KIT set up
Sets up HEPZATO KIT
Establish, monitor, controls, and ends extracorporeal pump and veno-venous bypass circuit



Coordinates with

Interventional Radiologist, Anesthesiologist,
(Surgical Oncologist), and procedural team



HEPZATO KIT PHP Procedure Team



Perfusionist



Pre-Procedure

- Warnings and precautions
- HEPZATO KIT components and non-KIT required accessories



Procedure

- Setting up the extracorporeal circuit
- Extracorporeal filtration circuit priming
- Connecting extracorporeal circuit to patient
- Monitoring anticoagulation status
- Bringing extracorporeal circulation “online”
- Managing and monitoring perfusion pump flow and pressures
- Preparing for and bringing filters “online”
- Monitoring and managing extracorporeal filtration system



Post-Procedure

- Preparing for and executing extracorporeal circuit shut down
- Disconnecting patient from extracorporeal circulation
- System breakdown and disposal



HEPZATO KIT Clinical Treatment Team

Pharmacist



Pharmacist



Experience

Preparation of chemotherapeutic agents using national and local safety guidelines



Communicates

During HEPZATO delivery



Responsibilities

Reconstitute HEPZATO
Deliver reconstituted HEPZATO to procedural room



Coordinates with

Medical/Surgical Oncologist,
Interventional Radiologist, Registered Nurse, Technicians



HEPZATO KIT Clinical Treatment Team



Pre-Procedure

- Store 5x5 HEPZATO Drug Pack in the Pharmacy



Procedure

- Prepare HEPZATO according to HEPZATO KIT USPI
- Coordinate timely delivery of HEPZATO to Interventional Radiology



Post-Procedure

- Discuss procedure for proper disposal of HEPZATO



HEPZATO KIT Clinical Treatment Team

Intensivist



Experience

Manage critical care patients



Communicates

With the medical or surgical oncologist and Interventional Radiologist



Responsibilities

Manages patient immediately post-procedure along with the SO/MO



Coordinates with

Anesthesiologist, Medical/Surgical Oncologist, Interventional Radiologist, Registered Nurse



HEPZATO KIT Clinical Treatment Team



Intensivist



Pre-Procedure

- Procedure induced physiological anomalies
- Procedural related complications



Procedure

- Complications and adverse reactions



Post-Procedure

- Manage hematology and administration of blood products
- Monitor hemodynamic status
- Monitor for bleeding at access sites and retroperitoneal

MODULE 3

Treatment Planning



Interventional Radiologist



Anesthesiologist



Perfusionist



Module 3 Purpose and Objectives

The introductory module provides a general overview of HEPZATO KIT and PHP procedure including target patient population and indication, contraindications, general safety and precautions, and clinical efficacy/safety information. Training will prepare HCPs for individual education modules based on specialized roles.



Identify patients who would be suitable candidates for HEPZATO KIT therapy.



Understand importance of pre-procedure imaging.



Know process for preparing patients for HEPZATO KIT procedure.



Understand options for hepatic artery mapping.



Patient Selection – Characteristics

There are suitable characteristics that reduce procedural/device related risks.



Inclusion

- Patients should have less than 50% liver tumor burden.
- Liver disease must be measured by CT or MRI.
- There can be limited extrahepatic disease at baseline if the life-threatening component of progressive disease is in the liver.
- Patients should have an ECOG score of 0 to 1 at screening.
- Prior chemotherapy, radiotherapy, chemoembolization, or Immunoembolization is allowed with a washout period of 30 days.

Patient Selection Process

Tumor burden assessed



Biopsy of the non-involved parenchyma



Clinical judgment and biopsy result used to guide the decision on performing the PHP procedure



HEPZATO KIT Preoperative Patient Assessment

After referral by the Medical Oncologist, a preoperative assessment of the patient is performed by the Anesthesiologist. A Cardiologist, and a Pulmonologist may be consulted for preoperative clearance indicating adequate cardiac and pulmonary function, as per each institution's process or protocol.

A patient may not be eligible for HEPZATO KIT treatment if any of the following are present:

Active coronary artery disease

Severe angina

Recent myocardial infarction

Any congestive heart failure

Significant ventricular arrhythmias

Moderate to severe valvular disease

Unable to withstand high dose vasopressor therapy

Advanced COPD

Unable to withstand mechanical ventilation



Treatment Planning and Preparation, Warnings & Precautions

Treatment Planning and Preparation

Treatment Planning



- No prior liver medical treatments within 4 weeks
- Screen for prior surgeries that could affect liver vascular anatomy
- Patients should have < 50% tumor burden

Treatment Preparation



- Patients should discontinue chronic anticoagulation therapies
- Patients must discontinue drugs treating hypertension
- Only manipulate intravascular catheters and fluoroscopic guidance
- Use caution to avoid air embolisms
- Contents are supplied sterile, inspect prior to use
- All components are single patient use only

Warnings and Precautions



- Peri-procedural complications (including hemorrhage, hepatocellular injury, and thromboembolic events)
- Myelosuppression
- Hypersensitivity Reactions
- GI Adverse Events (nausea, vomiting, abdominal pain, diarrhea)
- Carcinogenic/Mutagenic Effects
- Embryo-fetal toxicity
- Infertility

See Instructions For Use for detailed description of Warnings and Precautions



PHP Procedure Team Communication & Patient Preparation

PHP Procedure Team Communication Tasks

All HCPs should have an understanding and discussion on each expected task required before, during, and after the procedure

The procedural team should have a pre-procedure discussion

The procedural team should review the specific roles of each HCP throughout the procedure

Patient Preparation

The following exams, laboratory, or diagnostic tests should be performed to ensure patient fitness and eligibility such as



Fitness level



EKG



Blood tests: full blood count, liver function test, thrombophilia screen, urea, electrolytes



Likelihood of pregnancy status



List of current medications and allergies



Likelihood of menstruation during PHP procedure window



Pre-Procedure Exams (1)

The preoperative angiograms should include and enable:

Celiac and superior mesenteric artery injection

Evaluate the portal vein for patency during celiac and superior mesenteric arteriography.

The presence of significant portal venous hypertension is a contraindication for Melphalan/HDS

Completely examine the arterial supply to the liver and assess impact on chemotherapy infusion.

Evaluation of portal venous supply, including splenic, superior mesenteric and portal veins – to determine patency and direction of flow

Assessment for variant hepatic arterial and aberrant gastrointestinal (GI) branches – to prevent inadvertent infusion of GI or visceral branches



Pre-Procedure Exams (2)

The preoperative angiograms should include and enable:

Assess liver blood supply and formulate a strategy for catheter placement to ensure adequate drug infusion to the entire liver. If the risk assessment is unfavorable or the anatomic variation is too complex to allow whole liver or sequential lobar catheterization for safe delivery of melphalan, the procedure must not be performed.

A whole liver infusion (dosing) approach will likely require embolization of the gastroduodenal artery, but depends on its origin relative to the side branches of the distal proper hepatic artery. If the infusion catheter tip can be placed sufficiently distally to avoid retrograde reflux into the gastroduodenal artery, then the latter may not need to be embolized.

Depending on vascular anatomy, a sequential lobar approach may be the best administration option which requires splitting the melphalan dose. This will require repositioning of the catheter during the procedure.

Determination of optimal balloon spacing (50mm or 62mm)



Pre-Procedure Exams (3)



Embolization may be performed in order to avoid reflux or infusion into GI or Visceral arteries. Embolized areas may include the following vascular structures:

- ✓ Gastroduodenal artery (GDA)
- ✓ Left gastric artery (LGA), Right Gastric Artery (RGA)
- ✓ Hepatic variant anatomy (e.g., replaced hepatic artery)
- ✓ Aberrant or unusual anatomical variants



Pre-Operative Angiogram

Thorough search for any variant anatomy

Celiac and superior mesenteric artery mapping

Assessment of the hepatic arterial anatomy

Embolization of certain branches supplying the GI tract

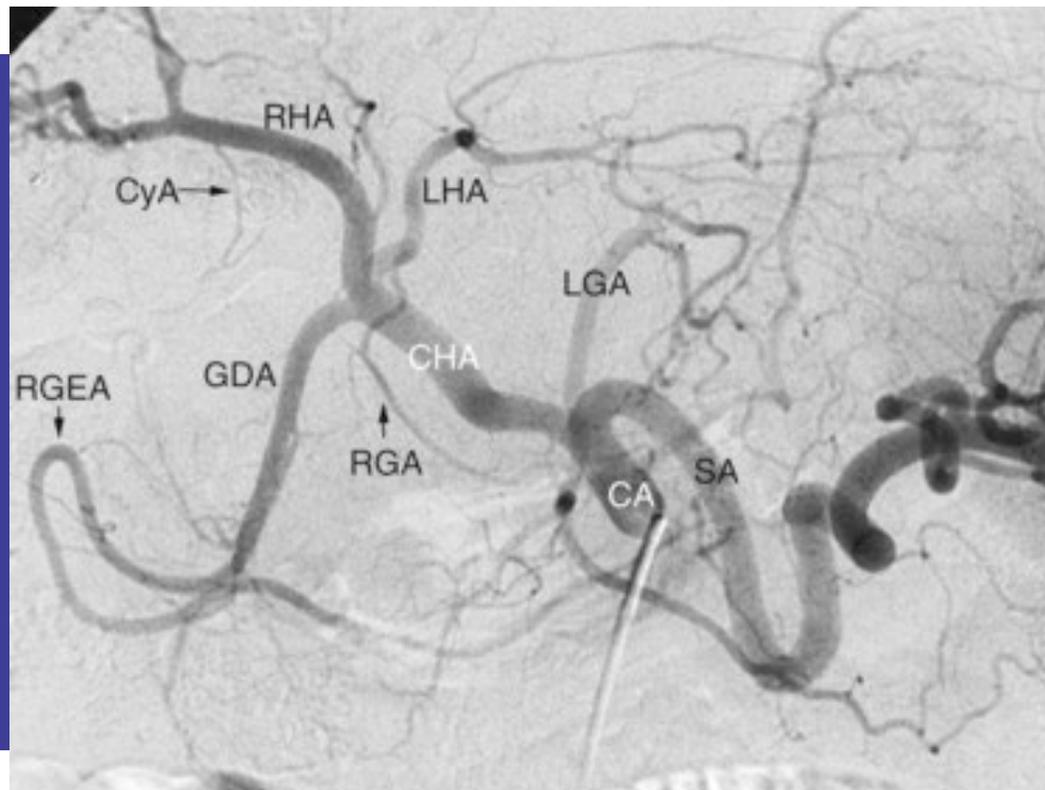

Assess tumor blood supply and formulate a strategy for catheter placement

Select HEPZATO KIT, for balloon spacing, based on patient anatomy

HEPZATO dose planning including whole liver vs lobar delivery

Conventional celiac artery anatomy. CA, celiac axis; LGA, left gastric artery; SA, splenic artery; CHA, common hepatic artery; GDA, gastroduodenal artery; RGA, right gastric artery; RHA, right hepatic artery; LHA, left hepatic artery; CyA, cystic artery; RGEA, right gastroepiploic artery.

Treatment planning options can consist of dosing based on a sequential lobar or whole liver approach.



Typical Schedule of Examinations Prior to PHP Procedure

3 Weeks Prior

- Baseline laboratory - medical history and physical examination
- Serum chemistries and electrolytes
- Complete blood count
- Baseline laboratory
- Concomitant disease
- Cardiac and pulmonary evaluation
- Liver function tests
- Prothrombin Time /Partial Thromboplastin Time
- Other medical tests as deemed necessary

2 Weeks Prior

- A baseline CT or MRI is acquired.
- This scan is needed to determine if there has been rapid advancement of the tumor from the time that the diagnostic scan was done.
- The extent of the disease is documented during this scan.
- Procedural risks are assessed including portal hypertension, liver cancer burden, cerebral bleeding risks and histories of surgical procedures.
- Hepatic Artery Mapping (has an optional time point)
- Pre-operative clearance

1 Week Prior

- Patient is screened for blood products.
- Blood Products (Type & Cross)
- Packed RBC, fresh frozen plasma, platelets, cryoprecipitate
- The preoperative hepatic artery mapping study may be performed.
- Pre-op medications prescribed
- Discontinuation of medications
- Hydration instructions
- Pre-op clearance



Procedure Preparation: Prior to Treatment (1)

Hydration | May be started the night before the procedure or the day of the procedure

Allopurinol (if tumor burden >25%) *As prophylaxis for electrolyte abnormalities, administer 300 mg/day orally 2–3 days before and 2-3 days following perfusion*

Proton Pump Inhibitors | To prevent gastritis which may occur as a result of regional melphalan absorption during the procedure, administer proton pump inhibitors

Anticoagulation |

- The patient will be systemically anticoagulated with heparin during the procedure.
- Administer heparin to the patient only AFTER placement of the 18F (femoral vein), 10F (jugular vein), and 5F (femoral artery) sheaths
- The patient must be fully heparinized prior to the insertion of the Double Balloon Catheter into the inferior vena cava. Begin with an initial intravenous bolus of heparin at 300 units/kg, dose adjusted to achieve activated clotting time.
- A minimum activated clotting time (ACT) of 400 seconds is necessary with a recommended ACT value > 450 seconds
- Evaluate activated clotting time frequently (approximately every 5 minutes) until adequate anti-coagulation is established (ACT > 400 seconds)
- DO NOT insert double balloon catheter into the patient until ACT values are > 400 seconds.
- Maintain activated clotting time at > 400 seconds throughout the procedure, assessing ACT values every 15 – 30 minutes depending on the patient's response and by administering intravenous heparin as needed.



Procedure Preparation: Prior to Treatment (2)



Anesthetic Management

Treatment must be administered with patients being monitored and under general anesthesia. Emergency resuscitation equipment must be available during the procedure.



Blood Pressure Control

Expect significant procedure related decrease of blood pressure when the balloons occlude blood return from the inferior vena cava (decreased cardiac inflow) and when the filters are brought into the extracorporeal bypass circuit. The reasons for filter-related hypotension are multifactorial, but hypersensitivity to non-physiological surfaces (inflammatory response), significant reduction in venous return and preload, and possible removal of catecholamines by the filters may play a role. To aid blood pressure maintenance for extracorporeal bypass, the following actions are recommended per institutional practice:

- Pre-operative hydration and intra-procedural administration of colloids and crystalloids.
- Vasopressor use in accordance with institutional practices to elevate mean arterial pressure to a target >65 mmHg
- Blood pressure must be constantly monitored throughout the procedure and maintained at levels required for adequate perfusion of critical end-organs (i.e., >65 mmHg).



Pre-Procedure Infusion Plan

Coordination with the Pharmacy

Prior to set up, provide pre-notification to the hospital pharmacy to be ready to prepare HEPZATO.

An actual request for drug preparation and delivery should be timed so that the start of the infusion of HEPZATO is within thirty minutes of preparation.

The filters should not be brought online until HEPZATO is in the procedure room. This minimizes filtration duration and associated complications.

Drug administration should be completed within 60 minutes of the start of preparation.

MODULE 4

Perfusion Circuit



Anesthesiologist



Perfusionist



Module 4 Objectives

Module 4 describes the responsibilities of the perfusionist in assembling the EFC and collaboration with the IR when connecting the patient to the extracorporeal circuit. HCPs will gain an understanding of the perfusion circuit components, setting up the system, managing the fluid path, connecting the system to the patient, bringing the filters online, troubleshooting flow related issues, and disconnecting the patient from the EFC.



Perfusionist



Understand and perform each step outlined in the IFU.



Interpret extracorporeal pump flow metrics.



Support proper anticoagulation in collaboration with the anesthesiologist.



Identify EFC issues and know how to resolve these problems.



Communication between the Perfusionist and the **other team members** is of **critical importance**.



Perfusionist Procedural Tasks

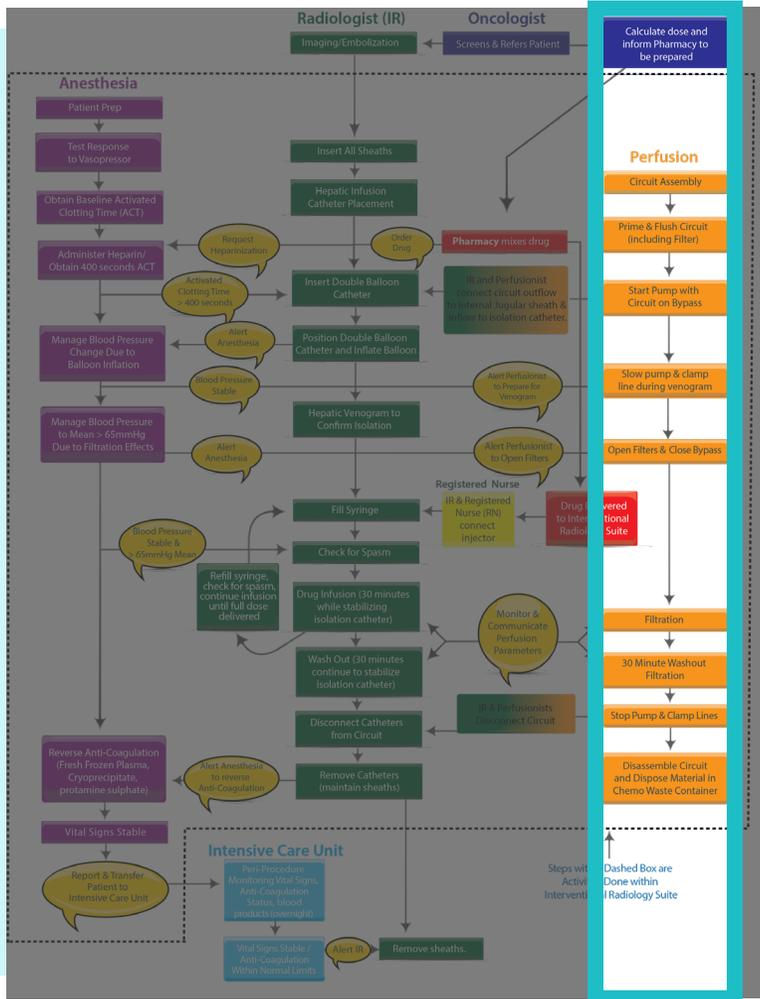

This module describes the steps the Perfusionist takes during the procedure



- Circuit Assembly
- Prime & Flush Circuit (including Filter)
- Start Pump with Circuit on Bypass
- Slow Pump & Clamp Line During Venogram
- Open Filters & Close Bypass
- Filtration
- 30 Minute Washout Filtration
- Stop Pump & Close Lines
- Disassemble Circuit and Dispose Material in Chemo Waste Container



HEPZATO KIT Components



Perfusionist

Perfusionist

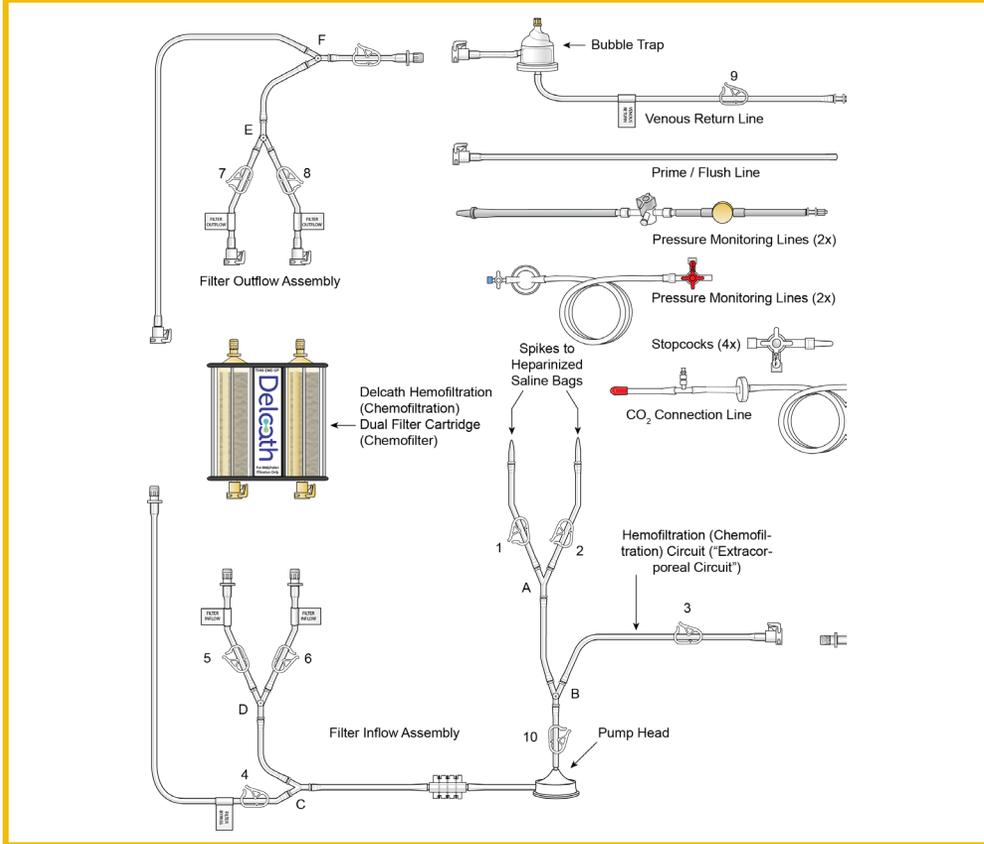

Interventional Radiologist

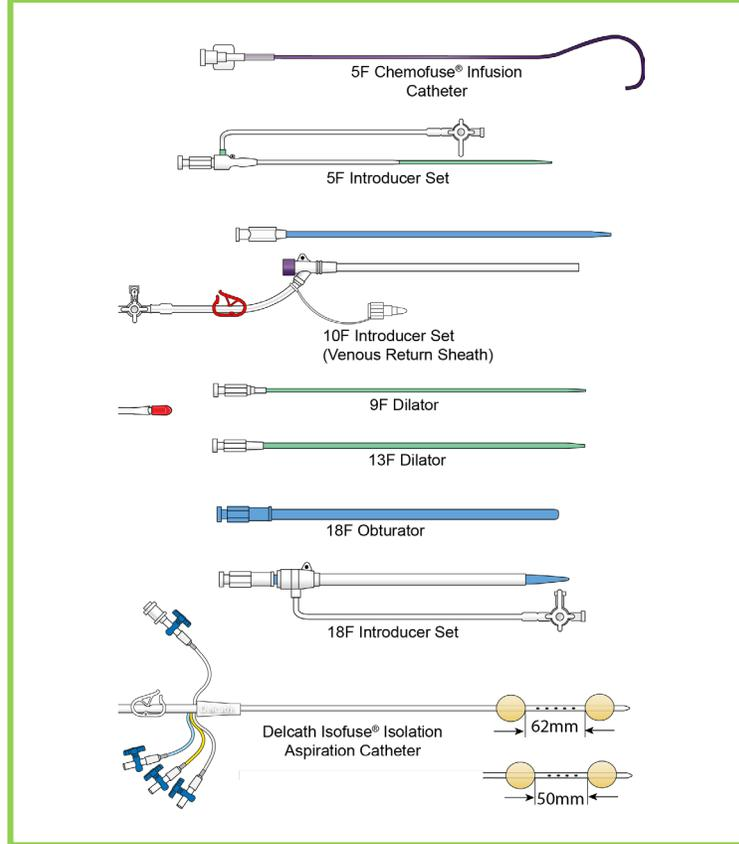

Only components provided in the Hepatic Delivery System or specified by Delcath in the Instructions For Use are to be used to create the circuit.

See IFU for full system description, including alphanumeric descriptions



HEPZATO KIT



Perfusionist

System Overview

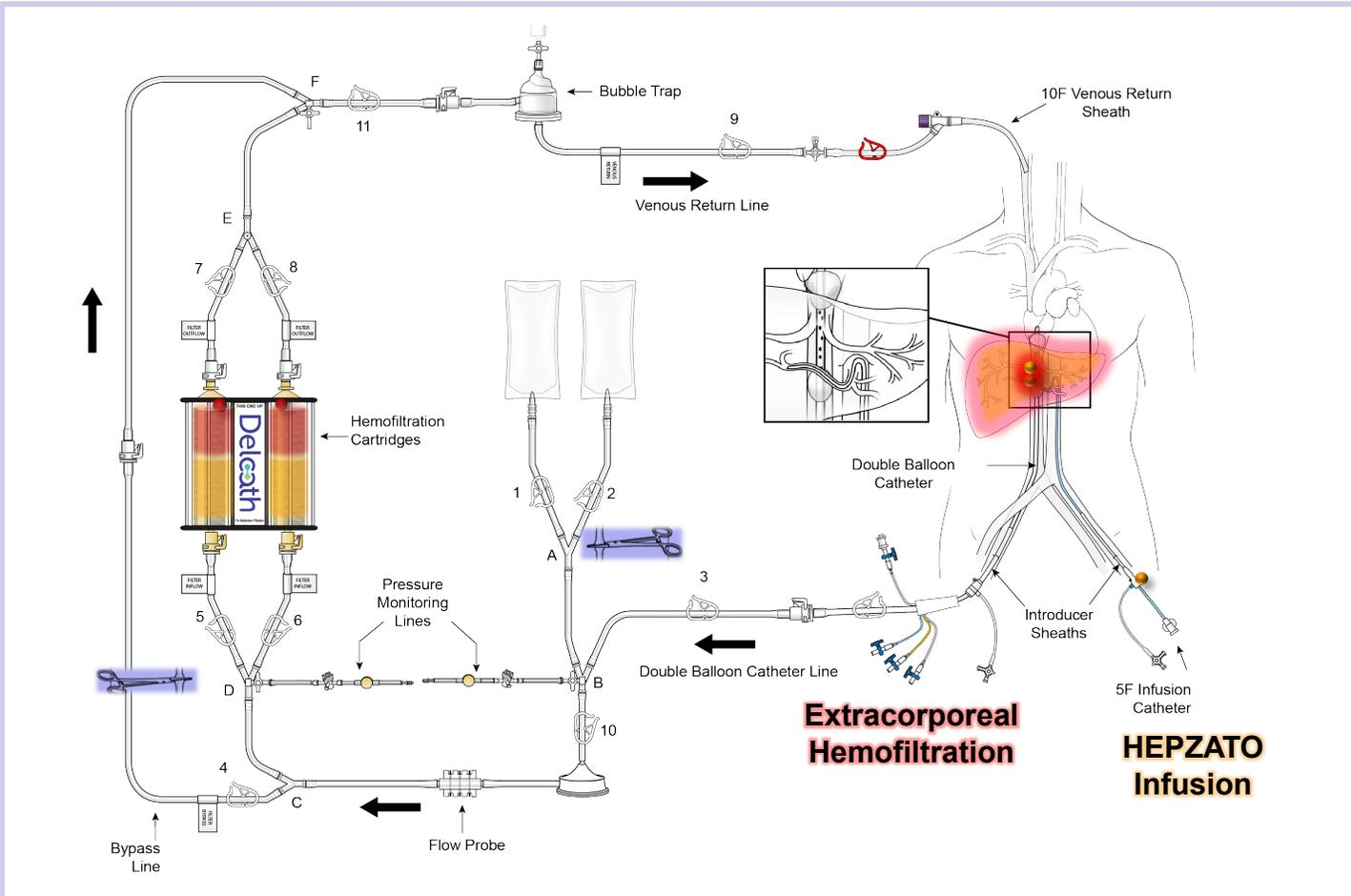

NOTE

Numbers 1-11 denote clamps used to control flow

Letters A-F denote Y-connectors

See IFU for full system description, including alphanumeric descriptions



1. Assemble the Extracorporeal Filtration Circuit

Circuit Assembly



Perfusionist

1

Prepare 9 liters of Heparinized Normal Saline

2

Remove Hemofiltration Dual Filter Cartridge from sterile pouch

3

Using guidance from the "THIS END UP" label on the faceplate, attach the filter to the intravenous pole using the built-in pole mount clamp.





Extracorporeal Filter Circuit Setup

Filter & Circuit Assembly

1. Open the circuit tray and remove the components in the pouches. Set aside for later assembly.
2. Remove the “**Filter Inflow Assembly**” section from the circuit tray, place pump head on the pump drive motor, and insert flow probe into flow transducer.
3. Connect the Inflow lines (circled in red in the image to the right) to the cartridge inlet connectors located on the bottom of the dual filter.
4. To complete the assembly, push the quick connector couplings together, as shown (circled in red; male to female) until an audible “click” is heard to verify connection.
5. Remove the “**Filter Outflow Assembly**” section from its sterile pouch.
6. Connect the two outflow lines to the filter cartridge outlet connectors located on the top of the dual filter using the quick connector couplings (circled in blue; push and click).
7. Assemble the two ends of the **Bypass line** by pushing the quick connectors together (circled in green; push and click).

Circuit Assembly



Perfusionist

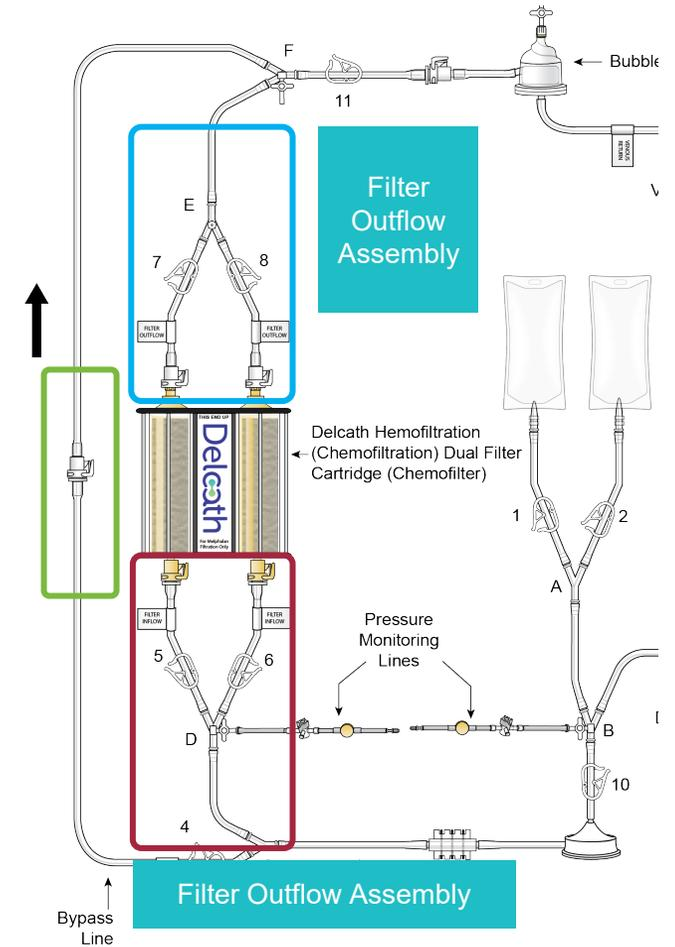



Extracorporeal Filter Circuit Setup

Prime Flush Line Assembly

Circuit Assembly



Perfusionist

- 1 Remove the “Prime/Flush Line” from its sterile pouch.
- 2 Attach the prime/flush line to the filter outflow assembly using the quick connect coupling located distal to “Y”-connector at F (blue arrow).
- 3 Place the open end of the “Prime/Flush Line” into the basin for collecting the flushed effluent during filter hydration (circled in red).

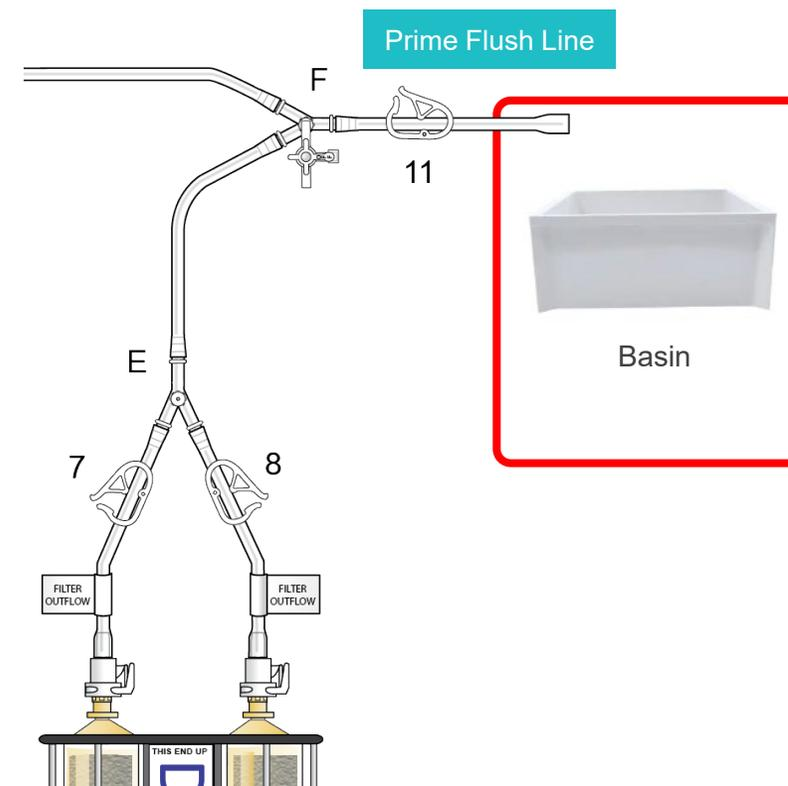



Extracorporeal Filter Circuit Setup

Stopcock Attachment Locations

Circuit Assembly



Perfusionist

1

Attach the supplied stopcocks as identified by the blue circles to ports:

“B”
(pre-pump head
pressure/suction)

“D”
(pre-filter pressure)

“F”
(outlet) Y-connector

2

Ensure all stopcocks are in the closed position (lever closed to the perfusion circuit).

3

Verify “Bypass Line” clamp 4 is open (Blue Arrow).

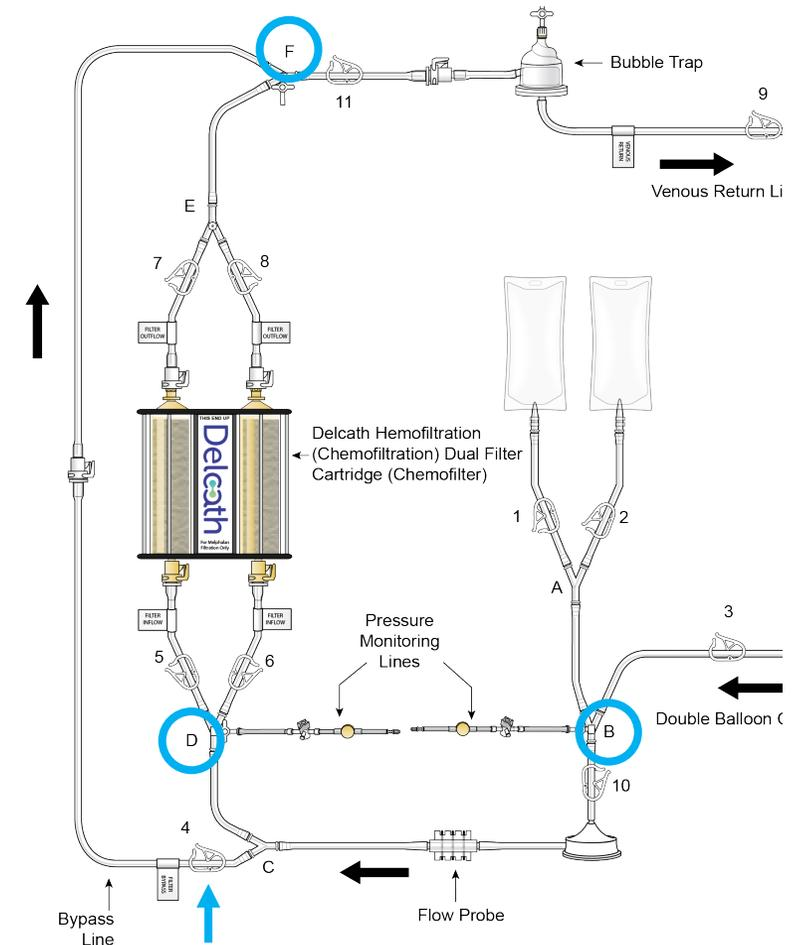



Extracorporeal Filter Circuit Setup

CO₂ Priming Connections

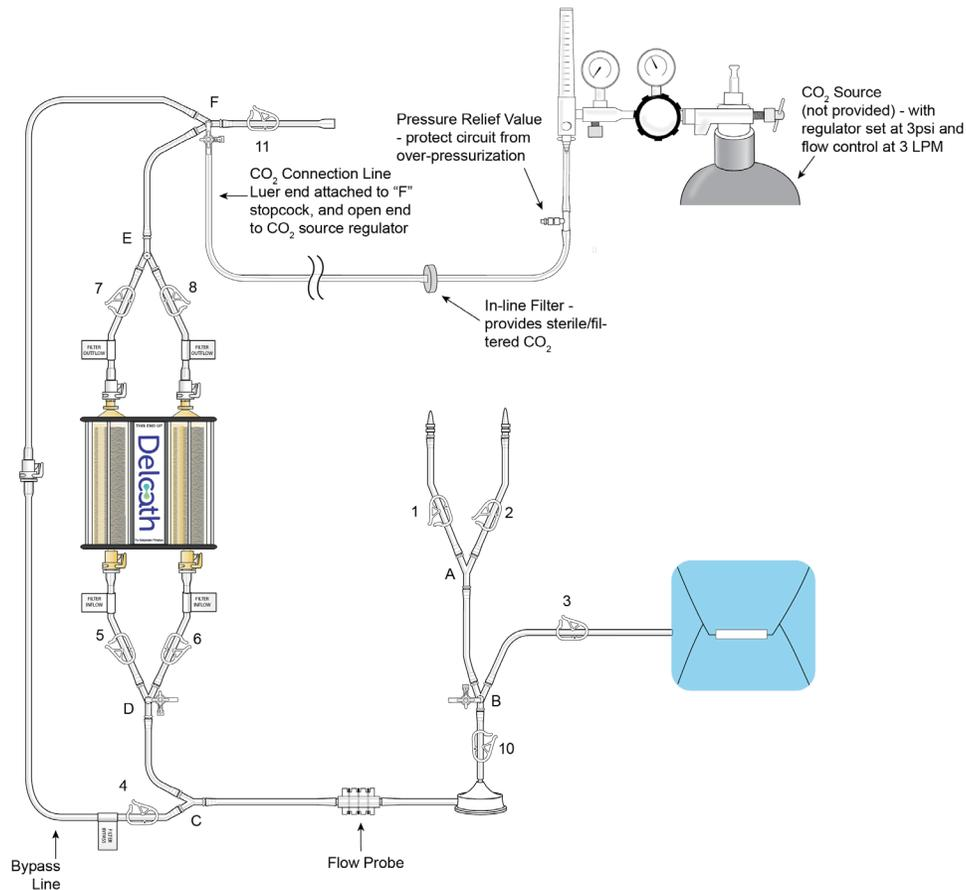

1. Close outlet clamp 11.
2. Attach the CO₂ connection line to the stopcock "F" and open the stopcock.
3. Connect the open end of the CO₂ connection line to the CO₂ source, and set the CO₂ source regulator to 3psi (approximately 3.0 liters per minute).
4. Start the CO₂ gas flow and allow the CO₂ to flow through the hemofiltration circuit.
5. Adjust CO₂ regulator to maintain 3psi (as necessary).



Extracorporeal Filter Circuit Setup

CO₂ Priming Connections

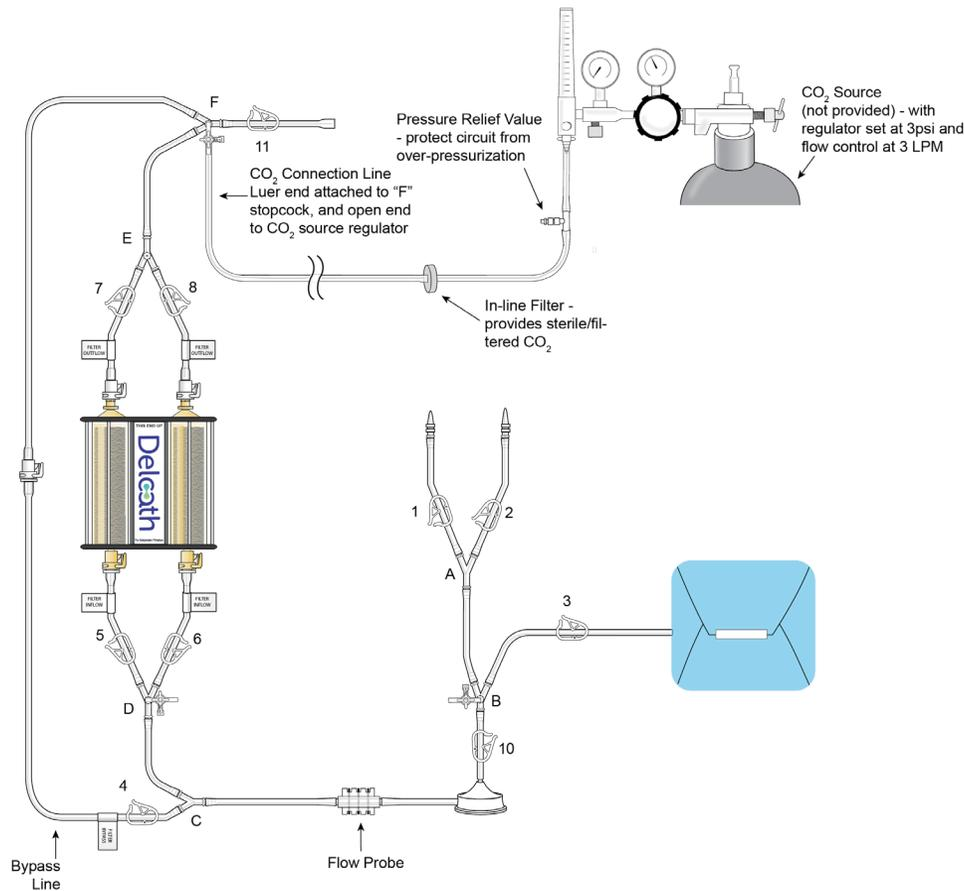

6. Verify CO₂ flow through the circuit.
7. Close bypass clamp (4) after approximately 1 minute to ensure flow through the hemofiltration cartridges.
8. Allow CO₂ to flow through the cartridges (after closing clamp 4) for at least 5 minutes.
9. Leave saline clamps 1 and 2 closed. Close double balloon catheter line, clamp 3. Close filter inlet clamps 5 and 6. Then close filter outlet clamps (7, 8) to lock CO₂ within the circuit.
10. Stop the CO₂ flow and close the stopcock "F" and disconnect the CO₂ connection line and discard.



Extracorporeal Filter Circuit Setup

Heparinized Saline Bags Connections

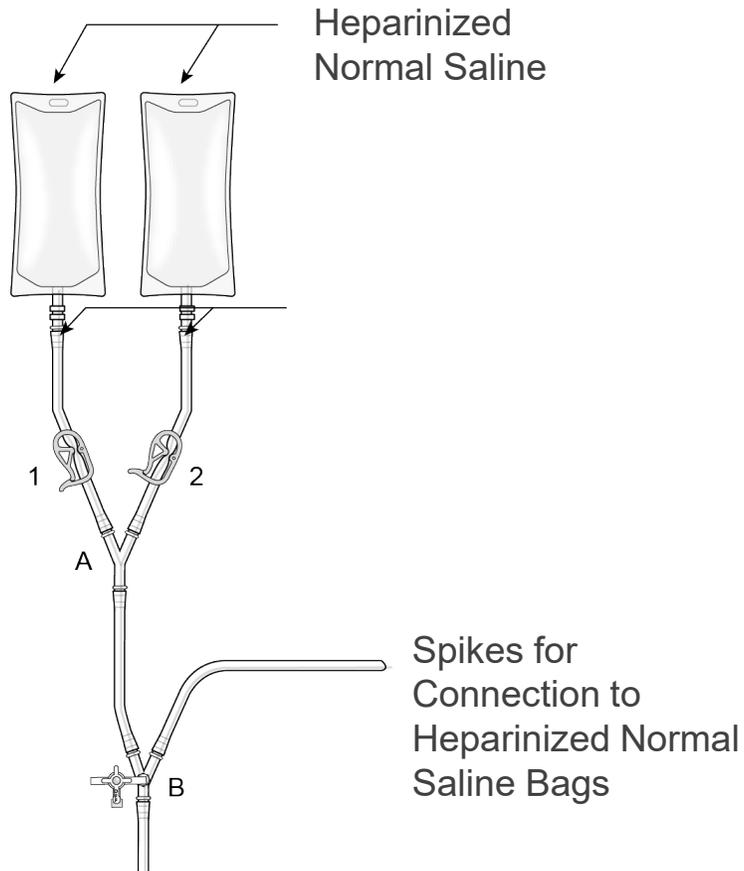

Hang two bags of the heparinized sterile normal saline and connect to circuit by using the spikes to allow for gravity priming of circuit components.

IMPORTANT: Use strict aseptic technique while spiking the heparinized normal saline bags.

Ensure there are two (2) liters of normal saline available for later use



Extracorporeal Filter Circuit Setup

Prime Double Balloon Catheter Line

Circuit Assembly



Perfusionist

1. Close pre-pump clamp 10.
2. Confirm that stopcock "B" is in the closed position (the lever is pointed toward the circuit tubing to the right).
3. Open double balloon catheter line clamp 3.
4. Open saline line (clamp 1 or 2), to allow heparinized normal saline to prime line only up to clamp 3, blue arrows demonstrating flow direction. Do not allow excess heparinized normal saline to fill sterile wrap.
5. Close clamp 3.

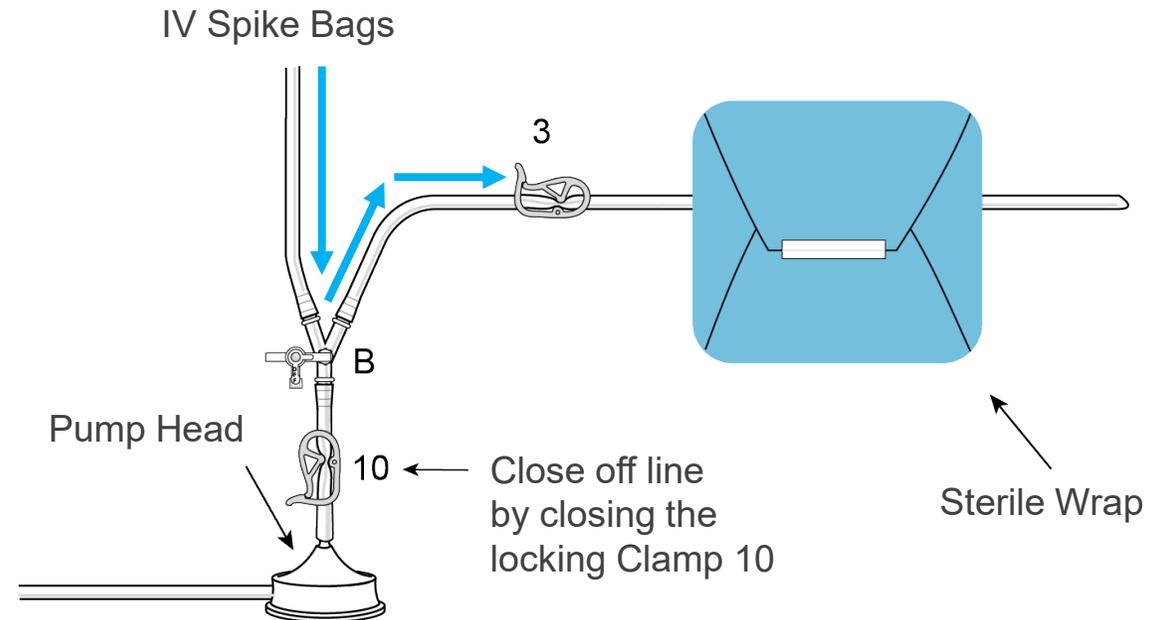



Extracorporeal Filter Circuit Setup

Prime Bypass Line



1

Inspect that stopcock "D" is in the closed position (the lever is pointed toward the circuit tubing to the left).

2

Prime the pump head and bypass lines by opening clamps 10 and 4.

3

Close clamp 4.

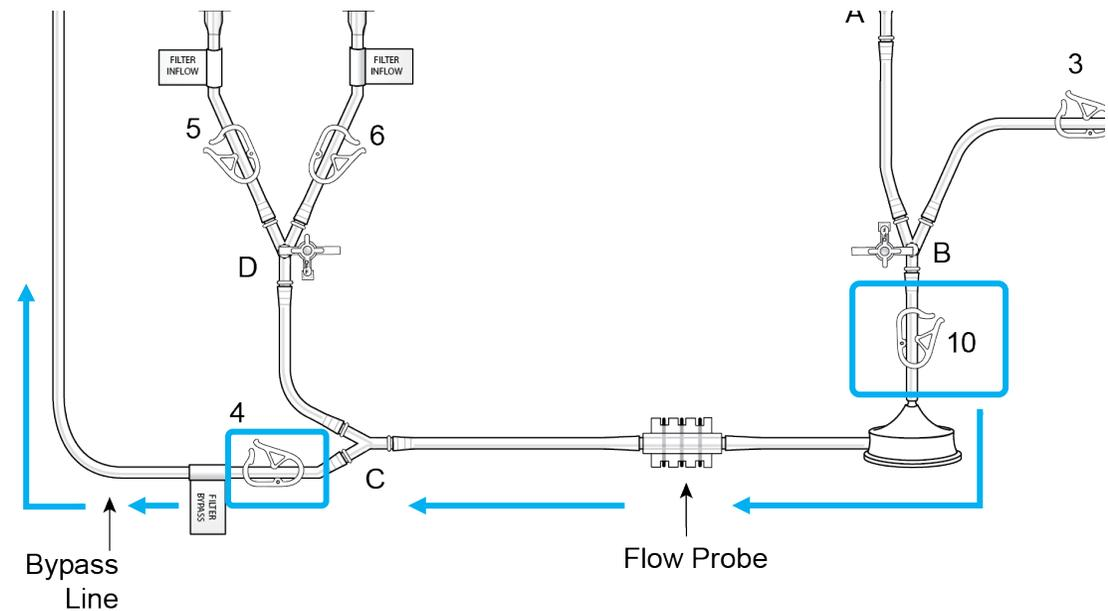



Extracorporeal Filter Circuit Setup

Prime Filter Cartridges

1. Inspect that stopcock "F" is in the closed position (the lever is pointed upward).
2. Open filter inlet clamps (5, 6).
3. Open filter outlet clamps (7, 8).
4. Open circuit outlet clamp (11).
5. Adjust the flow of heparinized normal saline into the filter to a suggested starting rate of 0.1 liters per minute (increasing slowly up to 0.5 liters per minute when the filters are completely filled). Note: Hemostats (forceps) are required to adjust flow rate if using gravity.
6. Note that filter cartridges will have a mottled appearance indicating the presence of gas bubbles.

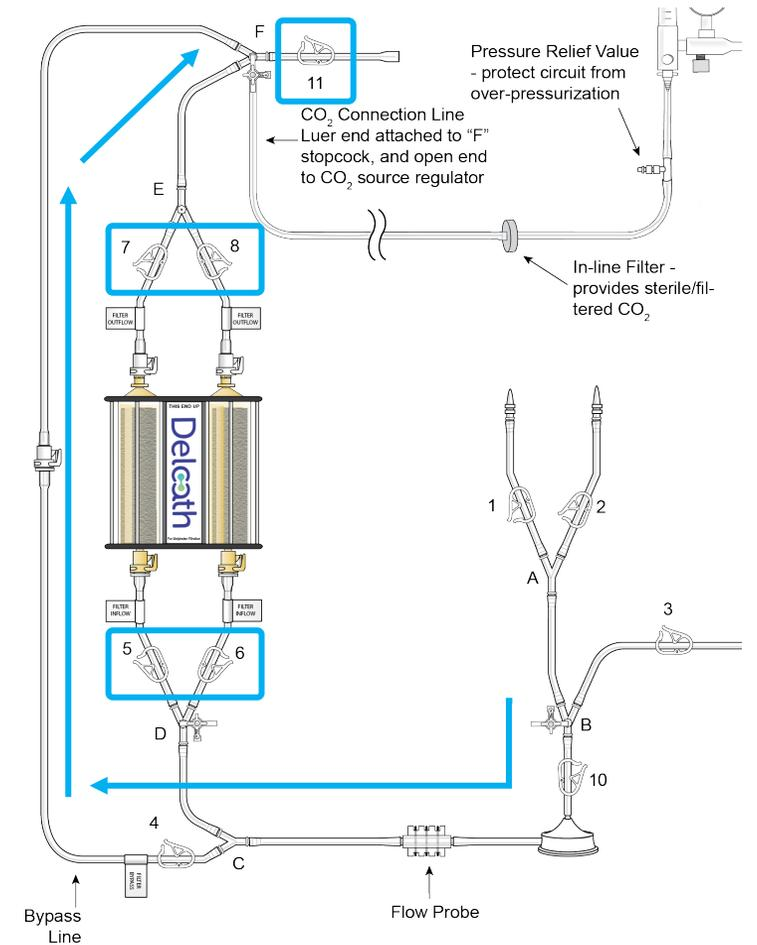
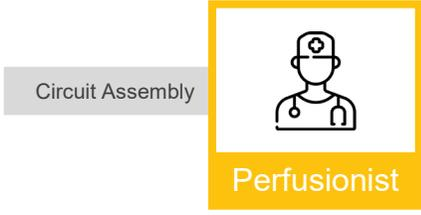



Extracorporeal Filter Circuit Setup

Prime Filter Cartridges

7. Allow heparinized normal saline to flow through the filters and out the “Prime/Flush Line” for approximately 6-10 minutes or until the filter appears gas free (solid black).
8. Once all gas appears to have been displaced, gently roll the cartridges between palm of hands to encourage trapped gas bubbles to rise. **CAUTION: Do not use excessive force when rolling the plastic housing.**
9. Inspect the entire cartridge for trapped gas by turning the cartridge within housing to visualize the entire filter. If there are gas bubbles gently roll the cartridges to free the trapped gas.
10. When Filter Cartridges are gas free, flush with an additional six (6) liters of heparinized normal saline (3 L/cartridge).
11. Close filter clamps 5, 6, 7, 8 and outlet clamp 11.

Circuit Assembly



Perfusionist

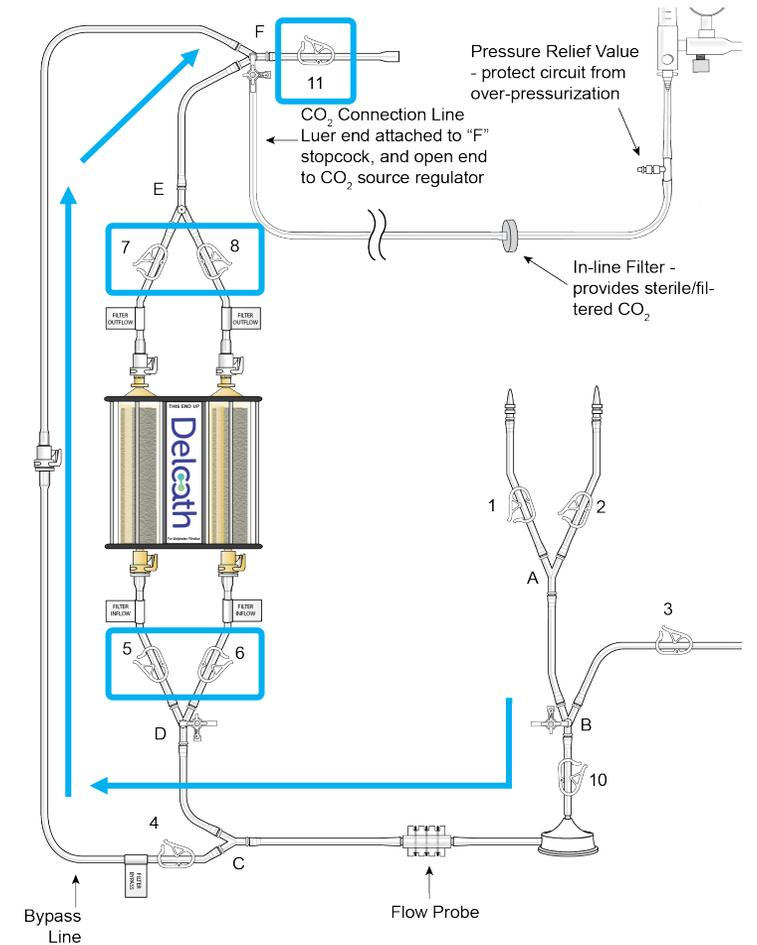



Extracorporeal Filter Circuit Setup

Prime Venous Return Line and Bubble Trap (1)

Circuit Assembly



Perfusionist

- 1 Disconnect and dispose of the “Prime/Flush Line”, by pressing in the latch located on the female quick connect coupling and pulling it apart.
- 2 Open the Venous Return sterile pouch and remove the venous return line and built-in bubble trap.
- 3 Attach the female to the male quick connector (push and click) located (blue arrow) by outlet clamp (11).
- 4 Position the bubble trap in the bubble trap holder higher than filter cartridges.

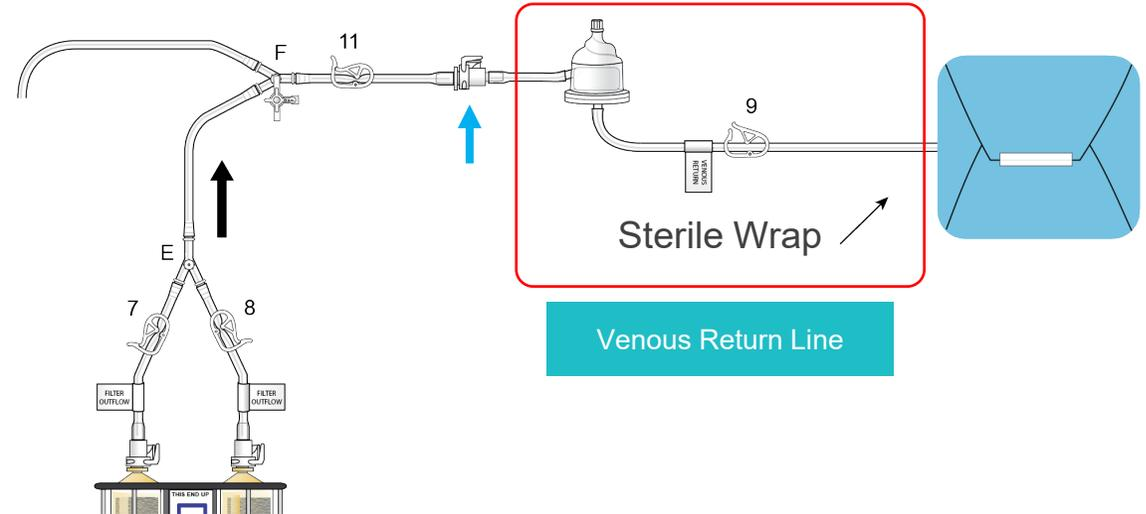



Extracorporeal Filter Circuit Setup

Prime Venous Return Line and Bubble Trap (2)

Circuit Assembly



Perfusionist

- 1 Attach stopcock to bubble trap and use syringe to aspirate air, as necessary.
- 2 Prime venous return line and bubble trap by opening clamps 4, 11 and 9.
- 3 Prime up to clamp 9. Do not allow saline to enter blue sterile pack.
- 4 Close clamp 9 once venous return line and bubble trap are primed up to clamp 9.

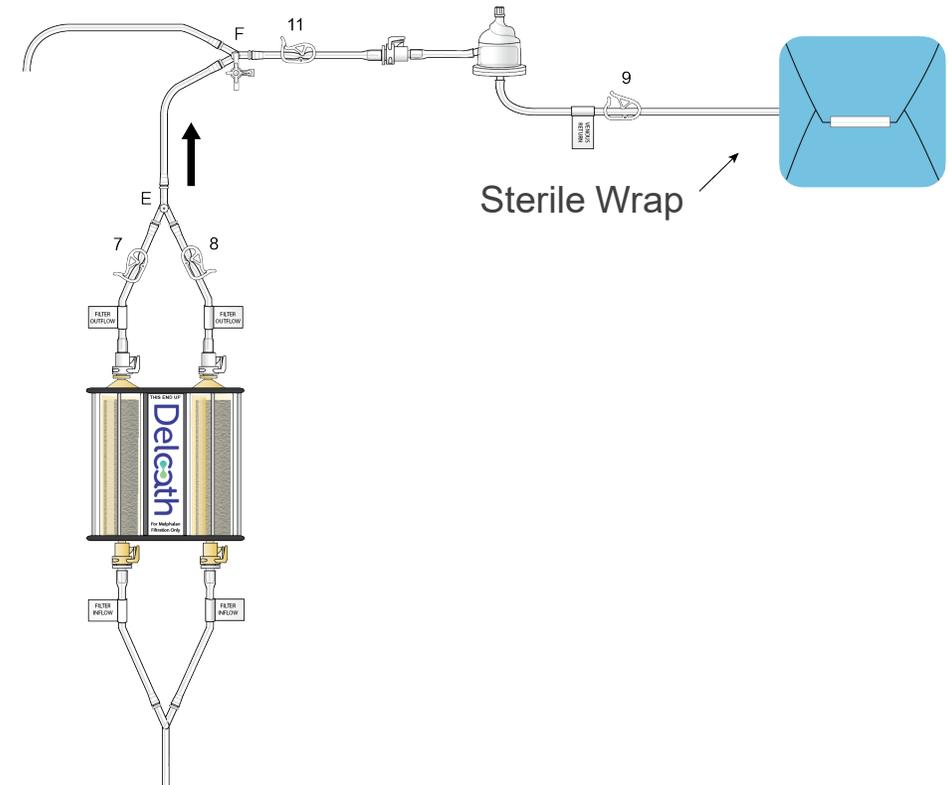



Extracorporeal Filter Circuit Setup

Pre-Pump Pressure Line Attachment & Priming (1)

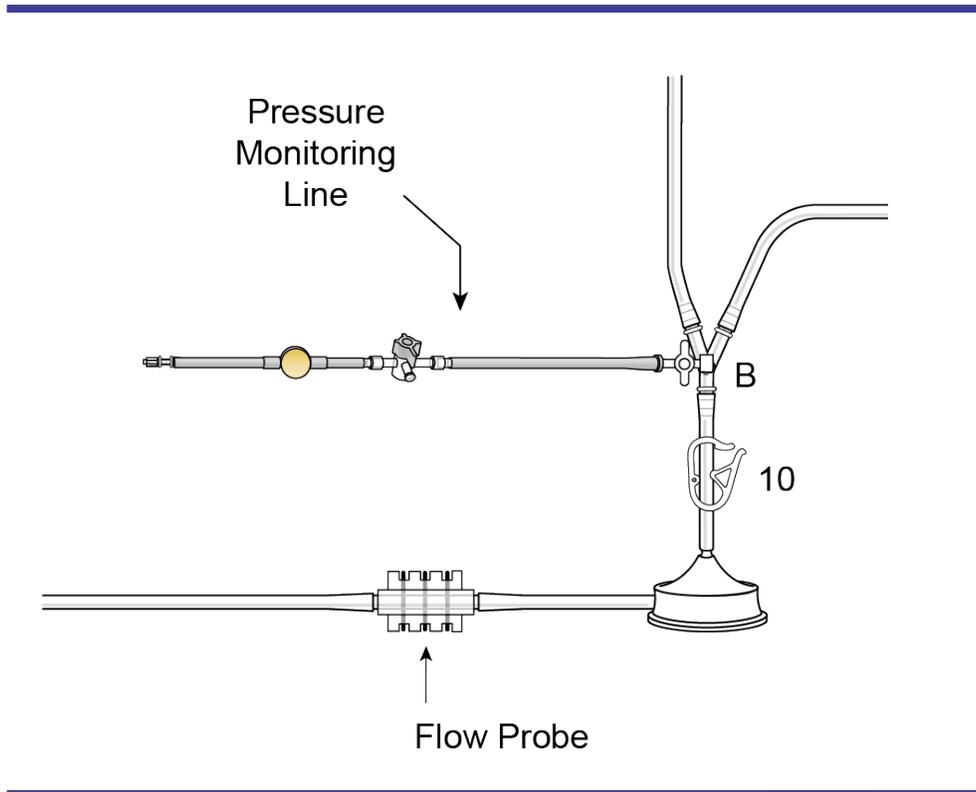

1

Attach pre-pump (to measure negative pressure – pump suction) pressure monitoring line to stopcock “B” and prime.



Extracorporeal Filter Circuit Setup

Pre-Pump Pressure Line Attachment & Priming (2)

Circuit Assembly



Perfusionist

- 1 Attach pre-filter (to measure positive pressure – pre-filter) pressure monitoring line to stopcock “D” and prime.
- 2 Attach the pressure monitoring lines to the P1 and P2 ports on the rear of the Medtronic Bio-Console 560 Speed Controller System.
- 3 Zero the pressure transducers (refer to Medtronic Bio-Console 560 System Manual for details).
- 4 Coiled pressure monitoring lines are included for use with DLP Pressure Display Boxes, as necessary.

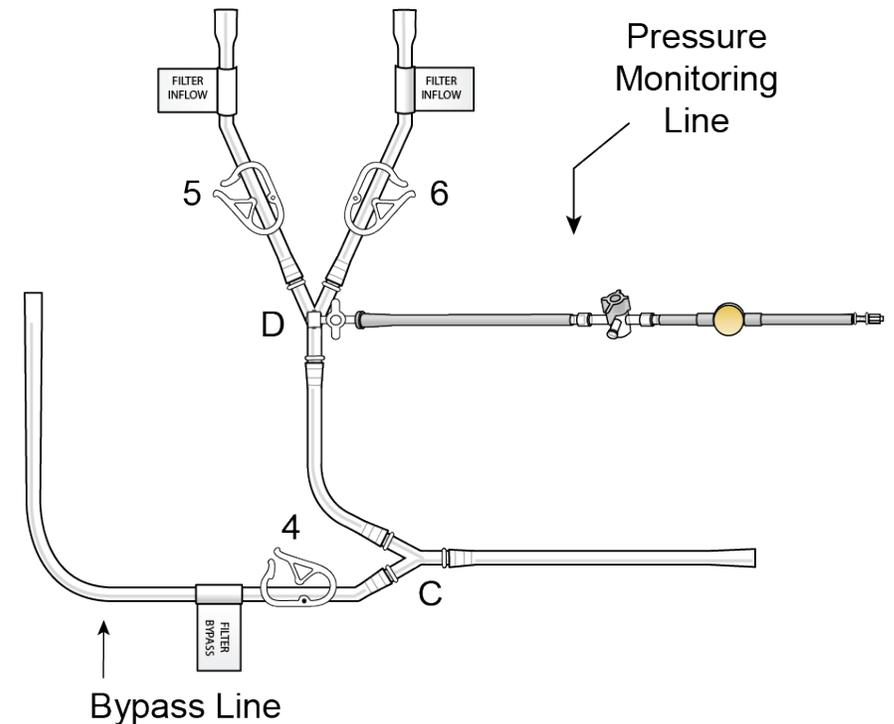



Extracorporeal Filter Circuit Setup

Pressure Test Circuits

Circuit Assembly



Perfusionist

- 1** Pressure test circuit by slowly ramping up the pump head speed (RPM) until a pressure reading of 300 mmHg is achieved on the pressure transducer attached to the line on Y-connector "D" (pre-filter).
- 2** Visually inspect all connections and cartridges to ensure no leaks are present.
- 3** Turn off pump and close cartridge inlet (5, 6) and outlet (7, 8) clamps. Ensure bypass line clamp (4) is open.
- 4** Ensure there are two liters of normal saline available for later use.
- 5** Warning: Ensure that all air is purged from the system prior to use in order to avoid an air embolism.

ECF System is now primed, hydrated, de-bubbled, and ready for use



Perfusionist Procedural Awareness

Pump Flow Rate

Circuit Assembly



Perfusionist

The flow rate of the pump should be maintained between 0.4 – 0.8 L/min

Pre pump pressure (suction side) should not be more negative than -250 mmHg, as lower pressures indicate possible catheter collapse or kink.

Pre-cartridge pressures (pre-filter) should not exceed 200 mmHg, as higher pressures indicate increasing filter resistance potentially due to thrombus or a kinked return line. Check filters to assure free flow and return line for kinks.





Procedural Team Awareness

Before Venovenous Bypass

Circuit Assembly



Perfusionist

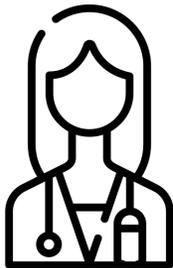

Chemotherapy HCP

Nurse/Tech Communicates:
HEPZATO has been delivered

Prior to opening the venovenous bypass circuit:

1

HEPZATO should be fully reconstituted and prepared for injection.

2

The activated clotting time should be > 400 seconds.

3

Vasopressor agents should be prepared and ready for injection.



Procedural Team Awareness

Veno-Venous Bypass

Circuit Assembly



Perfusionist

Pump Speed

Starting the Medtronic pump at a low speed to allow blood flow from the double balloon catheter into perfusion circuit.

Extracorporeal Filtration Circuit Clamps

It is important to open all of the clamps EXCEPT for the filter inlet and outlet clamps, which are clamps 5-8.

During veno-venous bypass, blood will bypass the filters and be returned to the internal jugular vein.

Blood pressure

Blood pressure should be carefully monitored, and the mean arterial pressure should be above 65 mmHg.



HCP Communications *Before* Bringing Filter Cartridges Online



Interventional
Radiologist

Interventional Radiologist Communicates:

“The hepatic veins are fully isolated”

“When to start and stop the pump”



Perfusionist

Slow Pump & Clamp Line During Venogram

Open Filters & Close Bypass

Filtration



Anesthesiologist

Anesthesiologist Communicates:

“MAP is > 65 mmHg”



Bringing Hemofiltration Cartridges Online

Open Filters and
Close Bypass



Perfusionist



Anesthesiologist



Anesthesiologist Communicates:

“Blood Pressure is...”

“MAP is controlled”

Leaving the bypass line open, open clamps on the left cartridge (5 and 7) and allow blood to displace the heparinized normal saline into the patient.

After the heparinized normal saline is in the left cartridge and its lines is fully replaced with blood, wait approximately 30 seconds and open clamps on the right cartridge (clamps 6 and 8), while keeping the bypass line open.

Once the heparinized normal saline in the right cartridge and its lines is fully replaced with blood, wait approximately 30 seconds and then close the bypass line by securely closing clamp 4.

Add a reusable tube clamp as a redundant bypass closure mechanism high on the bypass line in clear view of the team.

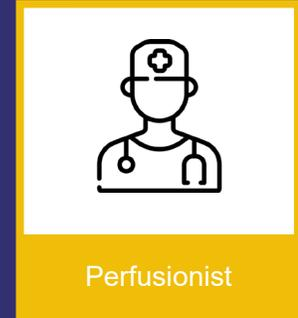

Perfusionist



Perfusionist Communicates:

“Filter 1 is open”

“Filter 2 is open”

“Bypass line is closed?”



Hemofiltration Cartridges Method

Filters brought online sequentially to limit large blood pressure reduction

Start Pump with
Circuit on Bypass

Slow pump & clamp
line during venogram



Perfusionist

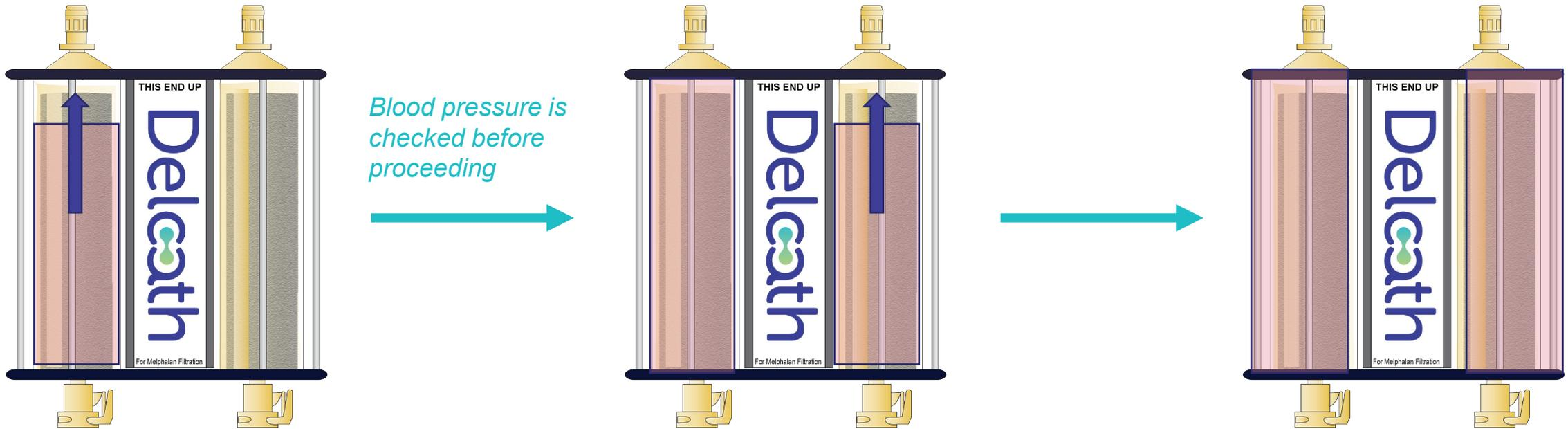

Left cartridge is
opened and charged first

Right cartridge is then
opened and charged

Complete Filtration
Established



Complete Hemofiltration

The tube clamp can be used to close the bypass line, at the area close to the upper Y connector and in easy view of the procedural team.

This will ensure that every HCP can see that the bypass line is closed during filtration.



Anesthesiologist



Anesthesiologist Communicates:

“Blood Pressure is...”

Open Filters & Close Bypass



Perfusionist

Filtration

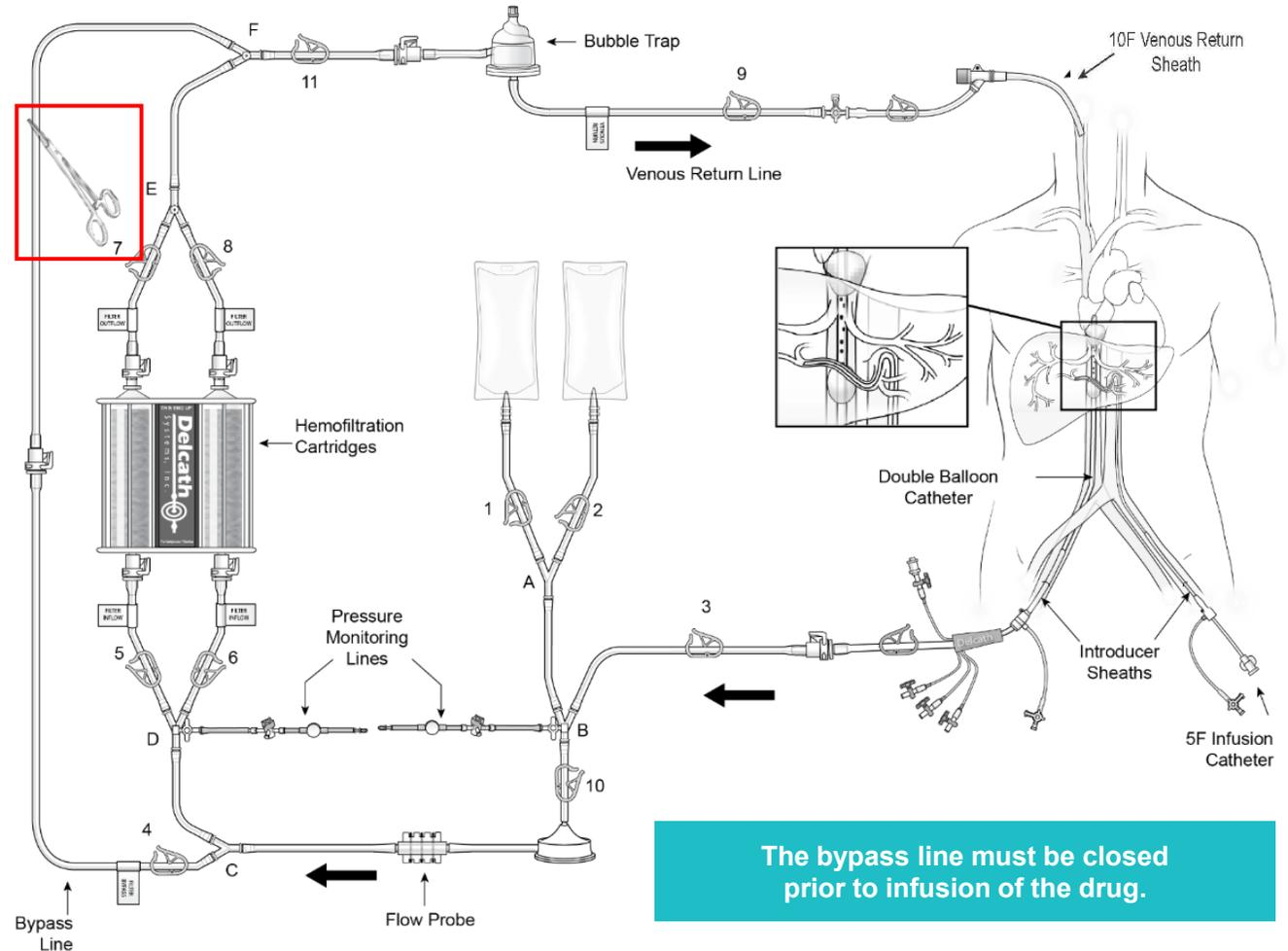

The bypass line must be closed prior to infusion of the drug.



PHP Procedure Monitored Events & PHP Team Member Roles



Perfusionist

Monitor Bubble-trap for entrapped air

Check for leaks from any part of the circuit

Monitor blood flow rate



Interventional Radiologist

Maintain DBC position

Spasm check

Check for DBC leaks

Positioning infusion catheter



Anesthesiologist

Monitor systolic, diastolic, and mean arterial blood pressure

Monitor heart rate and vital signs

Correct as needed



Establishing Hemofiltration

Blood Flow During Hemofiltration

Filtration



Perfusionist



Venous blood is aspirated from the central lumen through the fenestrations in the Isfuse Catheter



This blood flows through the Isfuse Catheter to the pump through the Bypass Line



Blood is returned to the patient through the venous return sheath

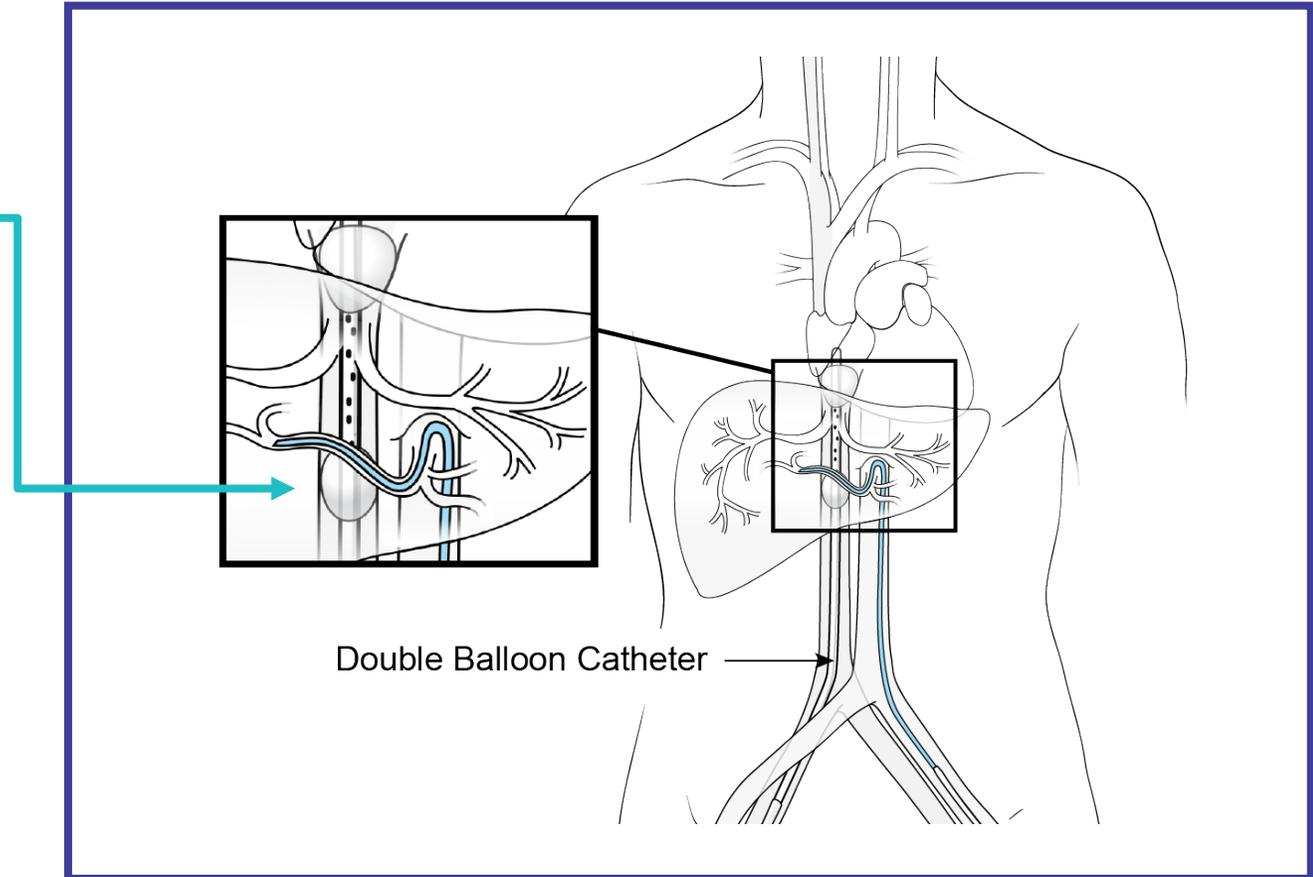



Procedure

Drug Infusion

Filtration

30 Minute
Washout Filtration



Perfusionist

Hemofiltration is maintained for

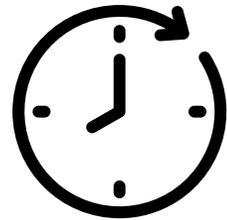

60 minutes

First 30 minutes:
Drug infusion phase

Last 30 minutes:
Washout period



Perfusionist

- Helps to maintain hemofiltration
- Monitors blood flow rate
- Monitors Pump Pressures
- Checks for circuit leaks
- Records ACT



Post Procedure

Blood Return

30 Minute
Washout Filtration



Perfusionist

To return blood to the patient the Interventional Radiologist instructs the Perfusionist to open clamps for saline flush and this pushes the blood through filter and back into patient's internal jugular vein.

The effectiveness of the return of blood to a patient is dependent on the central venous pressure and the amount of fluid given.





Ending Extracorporeal Circulation

Disassemble Circuit and
Dispose Material in
Chemo Waste Container



Perfusionist

At the end of the 30-minute wash-out period:

- 1 IR fully collapses the caudal balloon.
- 2 IR fully collapses the cephalad balloon.
- 3 Perfusionist discontinues filtration by:

Reducing the pump RPM to 1000

Closing clamps 3 and 9

Stopping flow by turning off the pump.

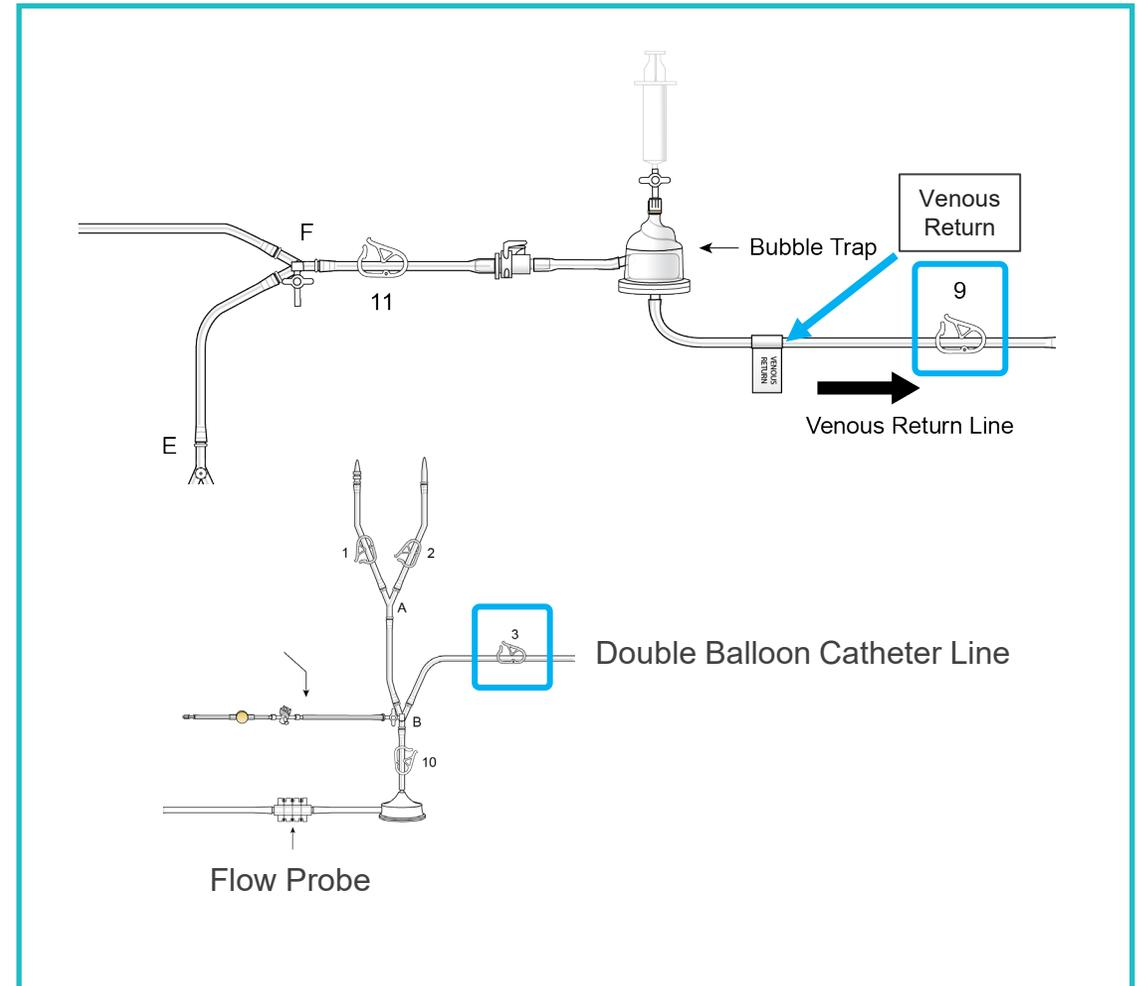



PHP Procedure Team End of Procedure Roles

Disassemble Circuit and
Dispose Material in
Chemo Waste Container



Perfusionist



Perfusionist

Stops all ECF flow

Opens bypass line

Assists with blood return

Appropriately disposes
all components



Interventional
Radiologist

Collapses DBC

Disconnects DBC

Disconnects internal
jugular introducer
from the ECF



Anesthesiologist

Vasopressor
weaned/discontinued

Normalizes
coagulation

Post procedural
medications



Perfusionist

MODULE 5

Drug Preparation and Injection



Module 5 Objectives

Module 5 describes the responsibilities of the pharmacists and interventional radiology nurse/technician who are responsible for the drug preparation and delivery system preparation, respectively.



Understand how to reconstitute, store and transport HEPZATO.



Coordinate timing of the prepared HEPZATO so delivery occurs as soon as possible to limit melphalan degradation and procedure time for the patient.





HEPZATO (melphalan) Injection

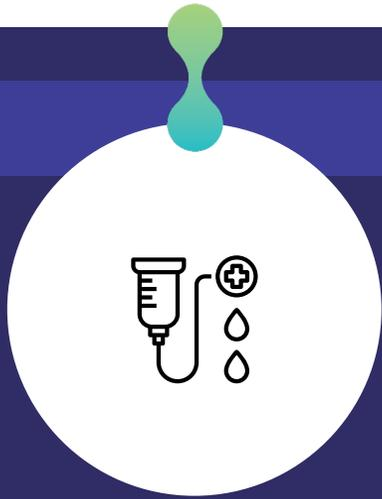
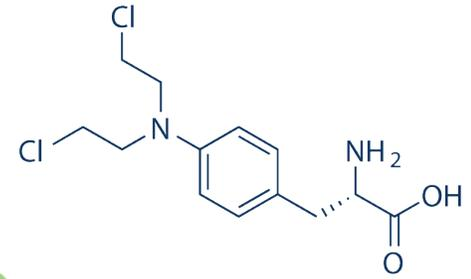

It is used as a chemotherapy.



It is also known as L-PAM or L-phenylalanine.

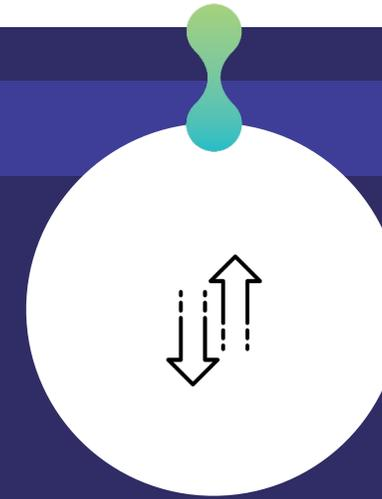

It is a bifunctional alkylating drug.

Vahrmeijer AL, van Dierendonck JH, Keizer HJ, Beijnen JH, Tollenaar RA, Pijl ME, et al. Increased local cytostatic drug exposure by isolated hepatic perfusion: a phase I clinical and pharmacologic evaluation of treatment with high dose melphalan in patients with colorectal cancer confined to the liver. Br J Cancer. 2000;82(9):1539–46.



HEPZATO (melphalan) for Injection

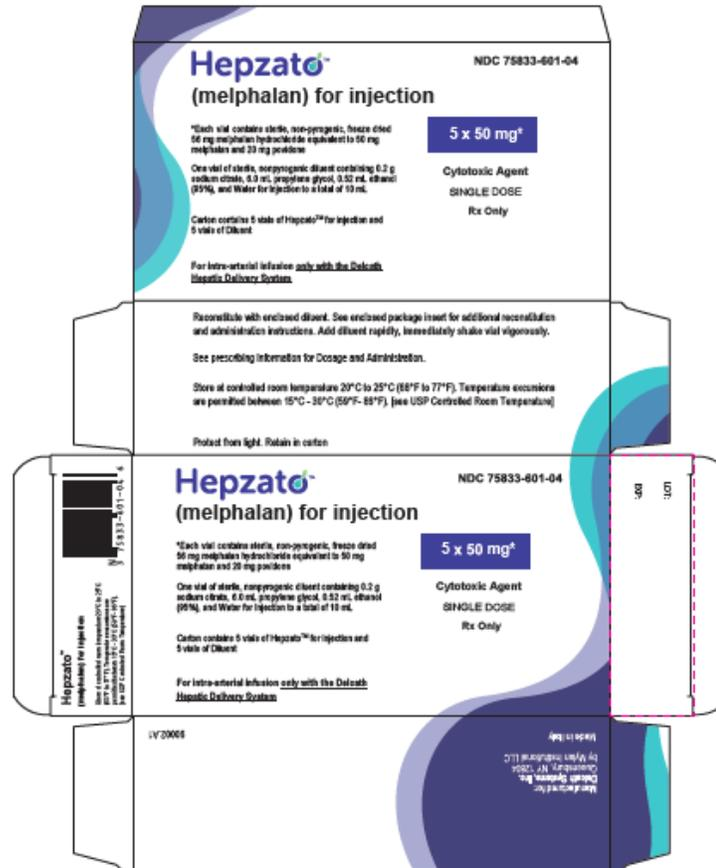

Each vial of HEPZATO for injection contains melphalan equivalent to 50 mg melphalan and 20 mg povidone



0.9% Sodium Chloride Injection is used as the approved secondary diluent

- Wear gloves in preparation and handling.
- If skin or mucosa contact is made, immediately wash with soap and water.
- Follow institutional guidelines and protocols.



Calculation of Ideal Body Weight for HEPZATO Dosing

	HEIGHT	IDEAL BODY WEIGHT
Men ♂	≥ 152 cm	52 kg + (0.75 kg/cm of height greater than 152 cm)
	< 152 cm	52 kg – (0.75 kg/cm of height less than 152 cm)
Women ♀	≥ 152 cm	49 kg + (0.67 kg/cm of height greater than 152 cm)
	< 152 cm	49 kg – (0.67 kg/cm of height less than 152 cm)

The HEPZATO dose may be calculated 1 to 2 days before the treatment by the Medical Oncologist.

TOTAL HEPZATO DOSE = CALCULATED IDEAL BODY WEIGHT X 3 MG

NOTE: Total dose not to exceed 220 mg.



HEPZATO Preparation

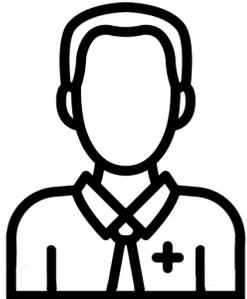

Pharmacist

Prepared by Pharmacy per physician's prescription

Reconstitute each HEPZATO vial with 10 mL of supplied diluent



Doses up to 110 mg

dilute reconstituted HEPZATO in **250 mL 0.9%** sodium chloride injection



Doses between 111 mg – 220 mg

dilute reconstituted HEPZATO in **500 mL 0.9%** sodium chloride injection

The 250 mL and 500 mL solutions will require multiple injection cycles



HEPZATO Preparation

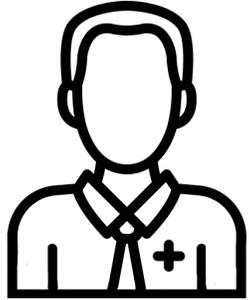

Pharmacist

Visual inspection for particulates
in HEPZATO solution



Chemotherapy HCP



IF PARTICULATES ARE OBSERVED DO NOT USE



HEPZATO Infusion Process

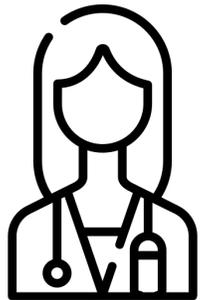

Chemotherapy HCP

**HEPZATO
solution
syringe refills**

Checks for:

- ✓ Hepatic artery spasms
- ✓ Balloon position confirmation
- ✓ Balloon expansion against vena cava walls



Interventional
Radiologist



HEPZATO Administration Injection Line Setup

Syringes

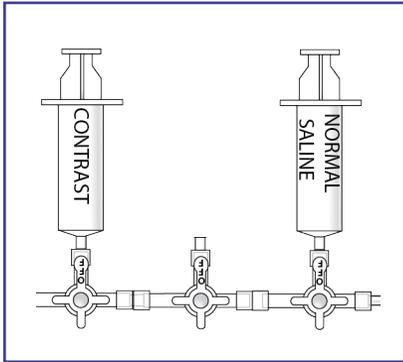

Undiluted iodinated contrast agent is attached to the injection line, and it is used for checking hepatic artery spasm via CT.

Nitroglycerin should be kept in the procedural room, and it must be administered intra-arterially to alleviate spasms.

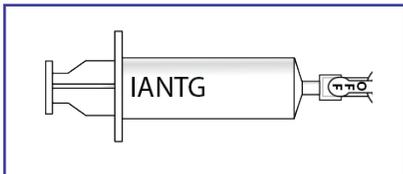

Normal saline is attached to the injection line, and it is drawn into the saline syringe for priming and flushing the hepatic arterial infusion line during the procedure.

Syringe	Volume and Concentration to Prepare in Syringe
Contrast	20 mL of undiluted iodinated contrast agent
IANTG	5 mL of diluted nitroglycerin 100 mcg/mL solution
Saline	20 mL of 0.9% Sodium Chloride injection



HEPZATO Administration Injection Line Setup

Catheter Connection

Note: this connection is done after drug arrives in the room.

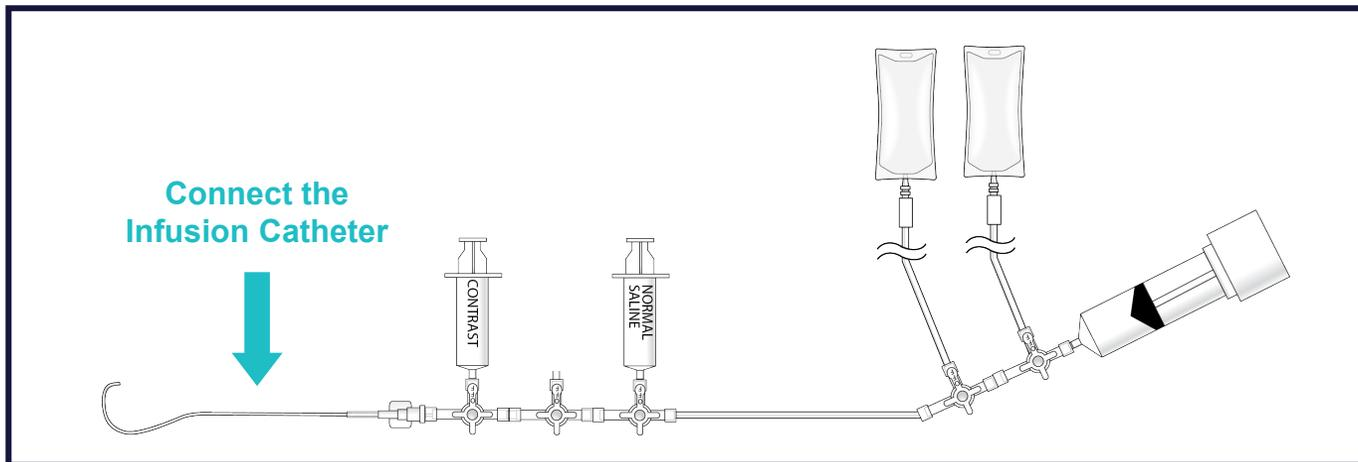

- Connect the Infusion Catheter (*5F catheter or a microcatheter coaxially introduced through the 5F catheter*).
- Maintain catheter patency by hospital catheter infusion protocols (*e.g., infuse heparinized saline: the concentration of heparin should be 1000 units per 500 mL of normal saline*).

Items needed but not included in HDS

- (1) Medrad 150 mL syringe
- (2) Intravenous Administration Sets
- (3) 48" Injector Lines
- (5) 3-way stopcocks
- (3) 20 mL syringes



HEPZATO Administration

Arterial Catheter

See IFU and USPI for complete HEPZATO information



HEPZATO is administered by infusion via a 5F arterial catheter or a Delcath-qualified microcatheter.



It is introduced coaxially through the 5F catheter into the proper hepatic artery.



At the discretion of the Interventional Radiologist, a microcatheter may be used when selective tip placement is preferred for the drug infusion.



Delcath has qualified three different microcatheters for use with the HEPZATO KIT.



Drug Injector System Setup

150 mL syringe
installed into the
drug injector

Injector flow rate
set to 25 mL/minute
OR 0.4 mL/second

Injection volume
entered 100 mL
per injection

Requires multiple
injection cycles



HEPZATO infusion
must be completely
administered within
30 minutes

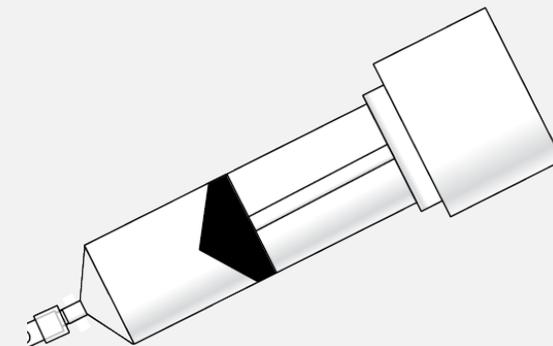



HEPZATO Drug Injector & Infusion Timing

Legend Key



HEPZATO Infusion

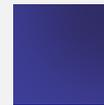

Refill Syringe. Check for Balloon/Catheter Placement & Spasm

500 mL Total Infusion (25 mL/min)

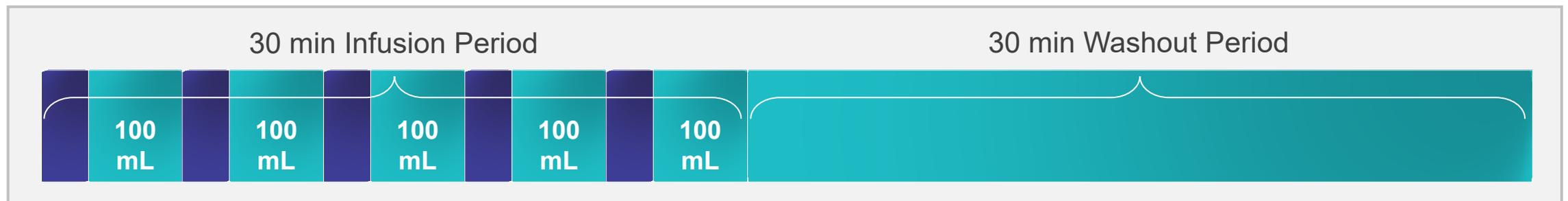

250 mL Total Infusion (25 mL/min)





HEPZATO Delivery Parameters & Precautions

DELIVERY PARAMETERS

TOTAL VOLUME OF
500 mL

5 infusions of 100 mL at 25mL/min

TOTAL VOLUME OF
250 mL

2 infusions of 100 mL + infusion of 50 mL at 25 mL/min

DELIVERY PRECAUTIONS



Immediately stop the procedure if leakage is detected outside of the isolated region and cannot be corrected.



Once the infusion of HEPZATO has started, Do NOT deflate balloons unless administration of drug has been stopped and a full washout cycle (30 minutes) has been completed.

MODULE 6

Procedure/Treatment Day



Interventional
Radiologist



Anesthesiologist



Perfusionist



Module 6 Objectives

Module 6 describes PHP Procedure Team responsibilities on the day of the procedure. This includes patient preparation and procedural methodology.

The content is specific for the IR, anesthesiologist, and perfusionist.



Describe required pre procedure imaging, laboratory testing, and medications.



Understand team coordination and intraprocedural communications.



Know procedure day medication, supplies and blood product needs.



Typical Schedule of Examinations Prior to PHP Procedure

3 Weeks Prior

- Baseline laboratory - medical history and physical examination
- Serum chemistries and electrolytes
- Complete blood count
- Baseline laboratory
- Concomitant disease
- Cardiac and pulmonary evaluation
- Liver function tests
- Prothrombin Time /Partial Thromboplastin Time
- Other medical tests as deemed necessary

2 Weeks Prior

- A baseline CT or MRI is acquired.
- This scan is needed to determine if there has been rapid advancement of the tumor from the time that the diagnostic scan was done.
- The extent of the disease is documented during this scan.
- Procedural risks are assessed including portal hypertension, liver cancer burden, cerebral bleeding risks and histories of surgical procedures.
- Hepatic Artery Mapping (has an optional time point)
- Pre-operative clearance

1 Week Prior

- Patient is screened for blood products.
- Blood Products (Type & Cross)
- Packed RBC, fresh frozen plasma, platelets, cryoprecipitate
- The preoperative hepatic artery mapping study may be performed.
- Pre-op medications prescribed
- Discontinuation of medications
- Hydration instructions
- Pre-op clearance



HEPZATO KIT Pre-Operative Activities

Ensure timely scheduling of preoperative activities

Imaging studies

Laboratory testing

Medication requirements
including new prescriptions



Procedural room reservation

Hospital bed reservation

Appointments with:
Medical Oncologist
Interventional Radiologist
Anesthesiologist



HEPZATO KIT Treatment Day Guidance

All medications and supportive measures must be determined and administered in accordance with:

Institutional policies,
guidelines, procedures

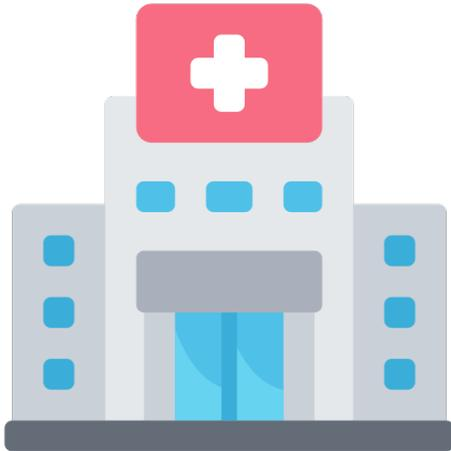

Delcath's Hepatic
Delivery System
Instructions For Use (IFU)



HEPZATO prescribing
information





Treatment Day Verifications

The Perfusionist verifies the following:

- 1 The expiration date, reference number, and lot number of the KIT.
- 2 The contents of the HEPZATO KIT.
- 3 Sets up the extracorporeal filtration circuit.
- 4 A full tank of CO₂ is in the procedural room.
- 5 The ACT machine is in the procedural room.



Perfusionist



Treatment Day Verifications

The Interventional Radiologist verifies the following:

- 1 The correct HEPZATO KIT (balloon spacing 50mm or 62mm) is in the procedure room.
- 2 The time that HEPZATO will be delivered by the pharmacy.
- 3 Any recent patient lab results which are pertinent to the procedure.
- 4 The treatment start time.
- 5 That all the medical materials needed for the procedure are in the operating room.
- 6 That all PHP Procedure team members are in attendance.



Interventional Radiologist



Treatment Day Verifications

The Anesthesiologist verifies the following:

1 The anesthesia medications are in the procedural room.

2 The vasopressor pump or line is set up.

3 There is patient access for delivery of medications.

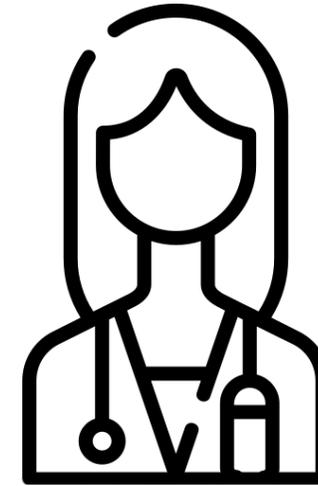

Anesthesiologist



Treatment Day Verifications

The Chemotherapy HCP verifies the following:

- 1 The drug injector is in the room.
- 2 The drug injector is set up.
- 3 The components that are not included in the HEPZATO KIT are available and organized on the Interventional Radiology suite's tables.

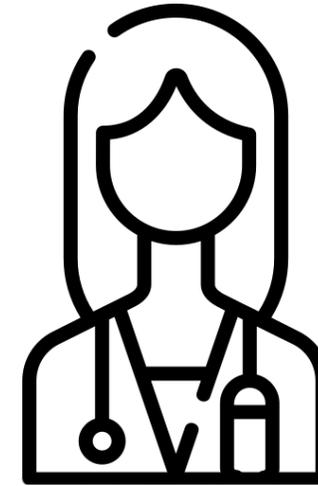

Chemotherapy HCP



Patient Treatment Day Preparation

The patient is:



- Provided with details on forbidden medications (oral anti-coagulants, ACE inhibitors, calcium channel blockers, alpha-1-adrenergic blockers, thrombin inhibitors, aspirin, NSAIDs)
- Provided with details about medications that will be administered during the procedure
- Administered pre-procedure medications



Hydration

The patient must be properly hydrated before the procedure.

Instructions are given to drink plenty of clear liquids prior to bed the night before the procedure.

Dehydration increases the risk of unstable blood pressure and difficulty maintaining mean arterial pressures above 65 mmHg.

Hydration is initiated at admittance to the hospital on the day of the procedure.

Excessive hydration pre-procedure or intra-procedure can increase post procedure complications. In some cases, excessive hydration may prolong mechanical ventilation due to head and neck edema.



PHP Procedure Team Roles and Responsibilities

ISOLATION



Interventional Radiologist

Catheterization
Placements

SATURATION



Perfusionist



Chemotherapy
HCP

Drug Infusion
Administration

FILTRATION



Perfusionist

Extracorporeal Circuit
Filtration Management



Medications that are Administered During the Procedure

All medications and supportive measures must be determined and administered in accordance with each institution's policies, guidelines, procedures.



Hydration

Necessary to compensate for procedural blood displacement



Heparin Anticoagulation

Maintain activated clotting time at > 400 seconds throughout the procedure



Anesthetic Management

Procedure is conducted under general anesthesia



Blood Pressure Control

Significant procedure-related blood pressure decrease expected
Maintain systemic blood pressure at >65 mmHg



Medications That Should Be Withheld



ACE inhibitors
Calcium channel blockers
Alpha 1 adrenergic blockers

Increase vasopressor resistance



Coumadin
Thrombin Inhibitors
Aspirin
NSAIDs

Increase procedural bleeding risks



Medications Delivered During the Procedure



Heparin

Maintain anticoagulation



Norepinephrine,
Epinephrine

For blood pressure management



Beta Blockers

Heart rate management *dependent on heart rate*



Treatment Day Angiogram

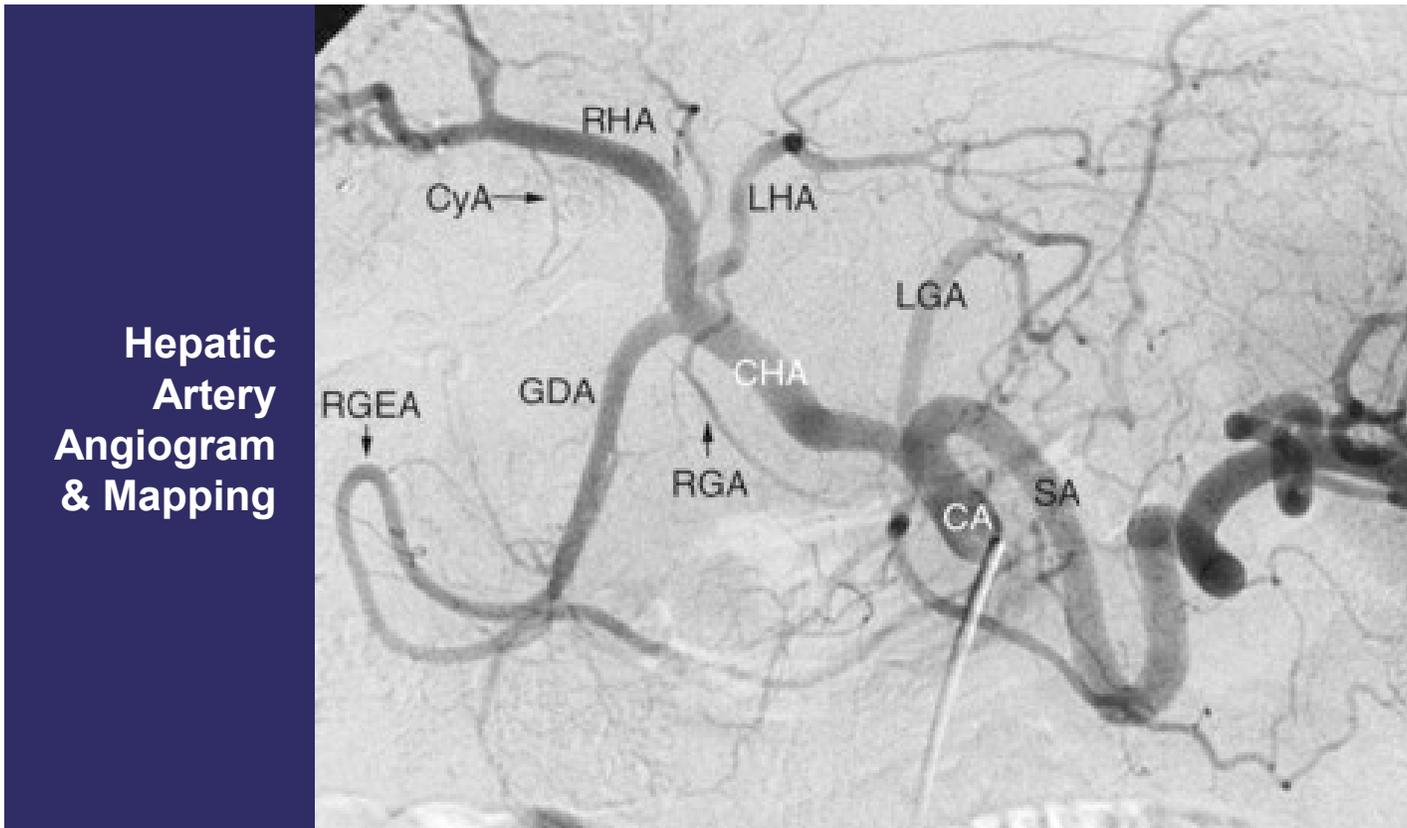

The arterial supply to the liver must be completely examined the day of the procedure if not previously done one week prior.

Determinations

*Possible impact of chemo infusion
Embolization needs*

Conventional celiac artery anatomy. CA, celiac axis; LGA, left gastric artery; SA, splenic artery; CHA, common hepatic artery; GDA, gastroduodenal artery; RGA, right gastric artery; RHA, right hepatic artery; LHA, left hepatic artery; CyA, cystic artery; RGEA, right gastroepiploic artery.



PHP Procedure Team Tasks and Key Communications



Each PHP Procedure Team member has separate workstreams during the procedure



There are critical points during the procedure where key information between the 3 PHP Procedure Team members needs to be shared



Natural pause points in the procedure, where all 3 PHP Procedure Team members must be aligned

the moment before Double Balloon Catheter (DBC) is expanded

when extracorporeal filtration begins

before drug delivery begins

Pre-Filtration

Inflate DBC, Begin Filtration

Deliver HEPZATO

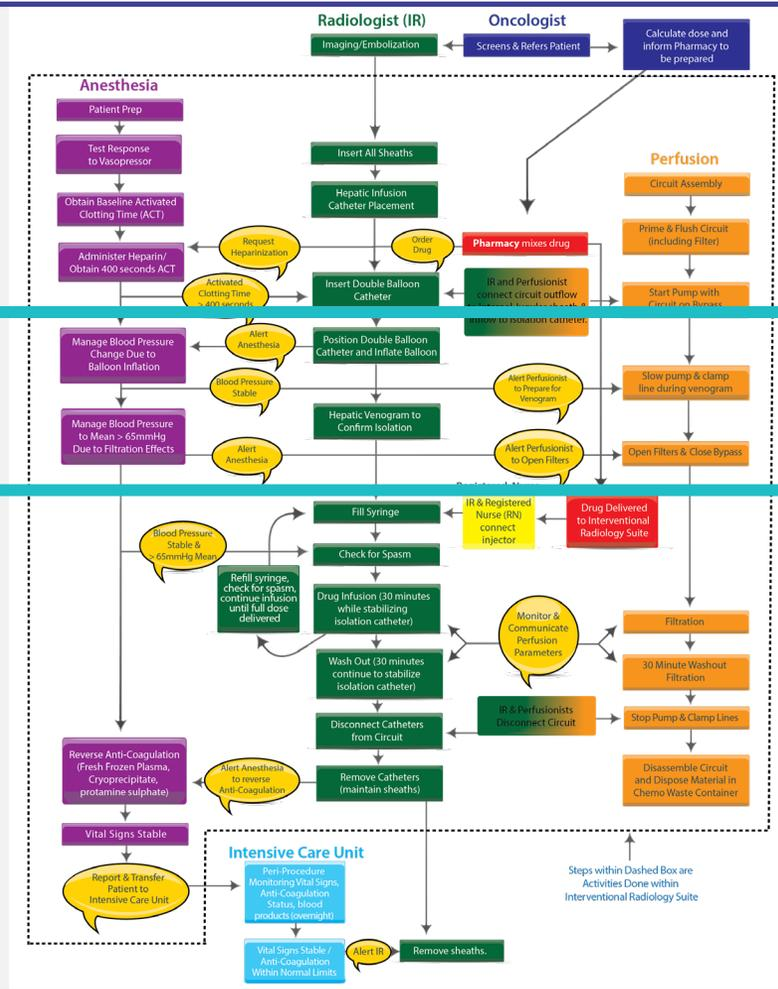



Prepare to Expand Double Balloon Catheter (DBC) and Bring the Filters “on-line”

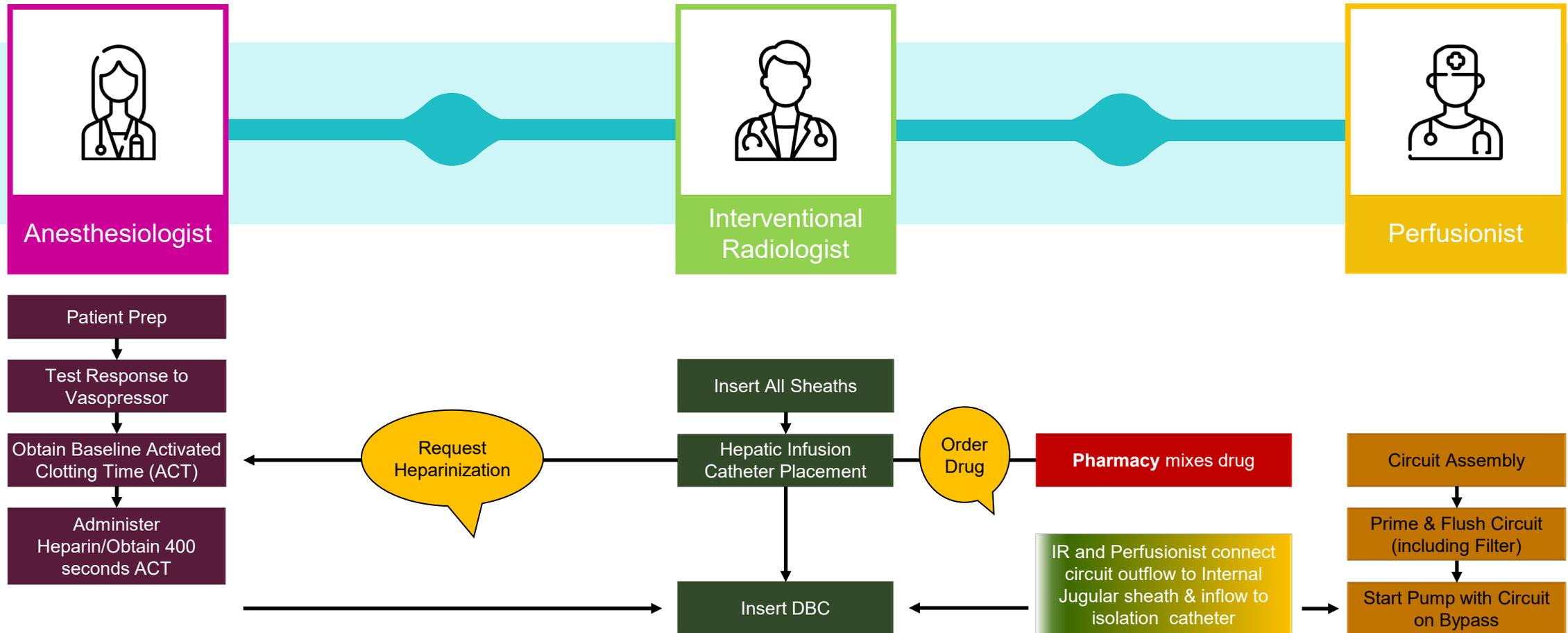



PHP Procedure Team tasks prior to Double Balloon Catheter (DBC) inflation and bringing filters on-line

Just prior to bringing the filter “on-line” the 3 PHP Procedure Team members should:



Anesthesiologist



*Request
Heparinization
Communicate
ACT Level*



- Complete patient preparation
- Test response to vasopressors
- Administer heparin
- Obtain a minimum 400 ACT
- Communicate the ACT to the IR



Interventional Radiologist



*Order
HEPZATO from
the Pharmacy*



- Insert all sheaths and catheters including:
 - Place Hepatic Infusion Catheter*
 - Place Double Balloon Catheter (without inflating balloons)*
- Order HEPZATO from the Pharmacy



Perfusionist

- Complete circuit assembly
- Prime and flush circuits (including filters)



Inflate Double Balloon Catheter (DBC), Bring Filters On-Line, and Deliver HEPZATO

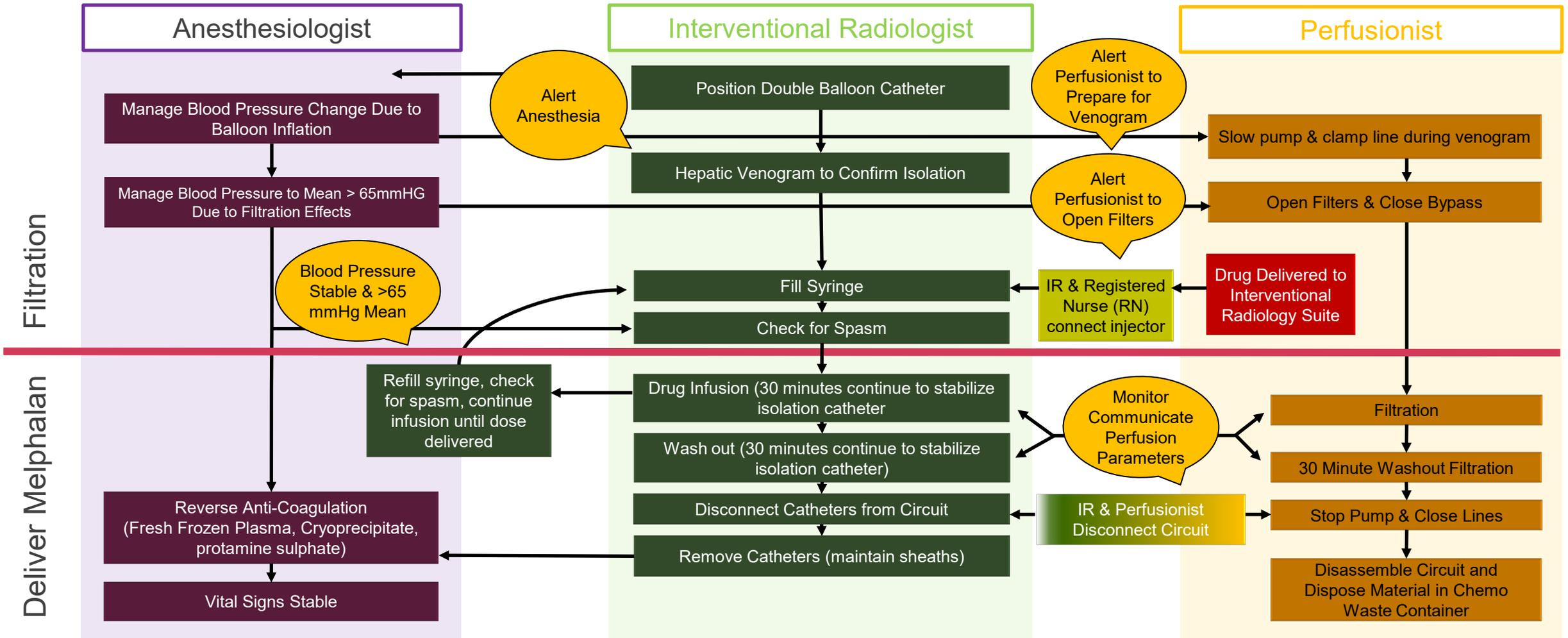



Bringing Filters on-line, Filtration, prior to HEPZATO Delivery



Anesthesiologist

*Communicate
blood pressures*

Manage blood pressure changes

Double Balloon Catheter (DBC) inflation

Bringing filters on-line

Maintain blood pressure mean > 65 mmHg



Interventional
Radiologist

*Alert Anesthesia prior to inflating DBC
Alert Perfusion to prepare for venogram
Alert Perfusion to open filters*

Position DBC

Inflate DBC

Conduct a hepatic venogram
to confirm isolation

Fill intra-arterial nitroglycerin syringe

Check for vascular spasms



Perfusionist

Start pump

Bring the filters on-line
one at a time (according
to IFU instructions)



HEPZATO Delivery, Washout and End of PHP Procedure



Anesthesiologist

*Communicate
blood pressures*

Manage blood pressure changes during
filtration/ HEPZATO delivery

Maintain blood pressure > 65 mmHg

Reverse anti-coagulation



Interventional
Radiologist

*Order drug infusion to RN
With Perfusion monitor and
communicate perfusion parameters*

HEPZATO infusion (30 minutes)

Wash out (30 minutes)

Disconnect catheters from circuit

Remove catheters and disconnect
circuit



Perfusionist

*With IR monitor and communicate
perfusion parameters*

Monitor filtration parameters

30 minutes melphalan filtration

30 minutes washout filtration

Stop pump and close lines

Disassemble circuit and dispose into
chemo waste container



Perfusionist Procedural Awareness

Pump Flow Rate



Perfusionist



The flow rate of the pump should be maintained between 0.4 – 0.8 L/min



Pre pump pressure (suction side) should not be more negative than –250 mmHg, as lower pressures indicate possible catheter collapse or kink.



Pre-cartridge pressures (pre-filter) should not exceed 200 mmHg, as higher pressures indicate increasing filter resistance potentially due to thrombus or a kinked return line. Check filters to assure free flow and return line for kinks.



IR Procedural Flow - Hepatic Artery Spasm

Once the blood pressure is stabilized the IR **injects contrast agent** to check for hepatic artery spasm.

IF SPASM IS OBSERVED:

POSSIBLE CAUSE	>	vasopressor therapy & low mean arterial pressure
EFFECT	>	reflux of melphalan into proximal non-embolized gastrointestinal branches or incomplete delivery of HEPZATO
DURING PROCEDURE	>	perform Angiography every 5 minutes
SPASM RELIEF	>	100 mcg/injection of intra-arterial nitroglycerin in hepatic artery

If there is a persistent intractable spasm, the procedure should be stopped.



IR Procedural Flow

Infusion, Filtration & Double Balloon Catheter (DBC) Management

Once the IR approves the start of HEPZATO infusion a 100 mL bolus is administered at 25 mL/second flow rate using drug injector (estimated 4 min infusion time).

The IR maintains a gentle hold of the DBC position during the entire infusion period.

HEPZATO is refilled into the drug injector and the IR performs a spasm check.

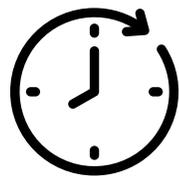

60 minutes

First 30 minutes:
HEPZATO Infusion

Last 30 minutes:
Washout period

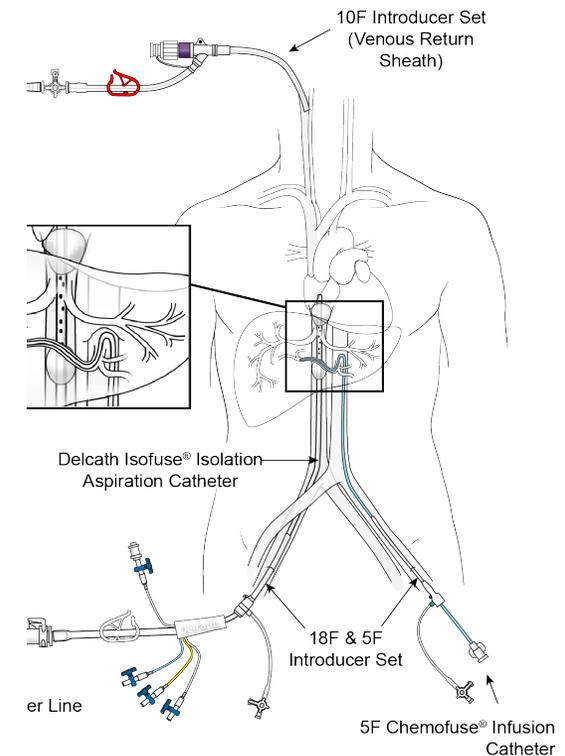

The DBC position checked fluoroscopically every 4 to 5 minutes during drug administration and filtration to ensure continued hepatic venous isolation



Post PHP Procedure

Blood Return

To return blood to the patient the Interventional Radiologist instructs the Perfusionist to open clamps for saline flush and this pushes the blood through the filter and back into the patient's internal jugular vein.

The effectiveness of the return of blood to the patient is dependent on the central venous pressure and the amount of fluid given.



End of PHP Procedure: Roles and Responsibilities



Perfusionist

Stops all Extracorporeal Filtration Circuit (EFC) flow

Opens bypass line

Assists with blood return

Appropriately disposes all components



Interventional Radiologist

Collapses Double Balloon Catheter (DBC)

Disconnects DBC

Disconnects internal jugular introducer from the EFC



Anesthesiologist

Vasopressor weaned/discontinued

Normalizes coagulation

Administers post procedural medications



Interventional
Radiologist



Perfusionist

MODULE 7

Catheterization, Isolation & Saturation



Module 7 Objectives

Module 7 describes the responsibilities of the Interventional Radiologist (IR) on the day of the procedure. This includes catheterization, hepatic isolation, and contrast administration during drug infusion.

- Properly insert and place introducers and catheters.
- Understand procedural techniques that affect filter efficacy and systemic melphalan exposure.
- Confirm hepatic artery anatomy, determining whole liver vs lobar infusion approach and optimal hepatic artery catheter location.
- Assess appropriate Double Balloon Catheter (DBC) position and stabilization.
- Understand process to administer HEPZATO and how to split HEPZATO dose for sequential lobar approach.



Interventional Radiologist Procedural Tasks



Interventional Radiologist

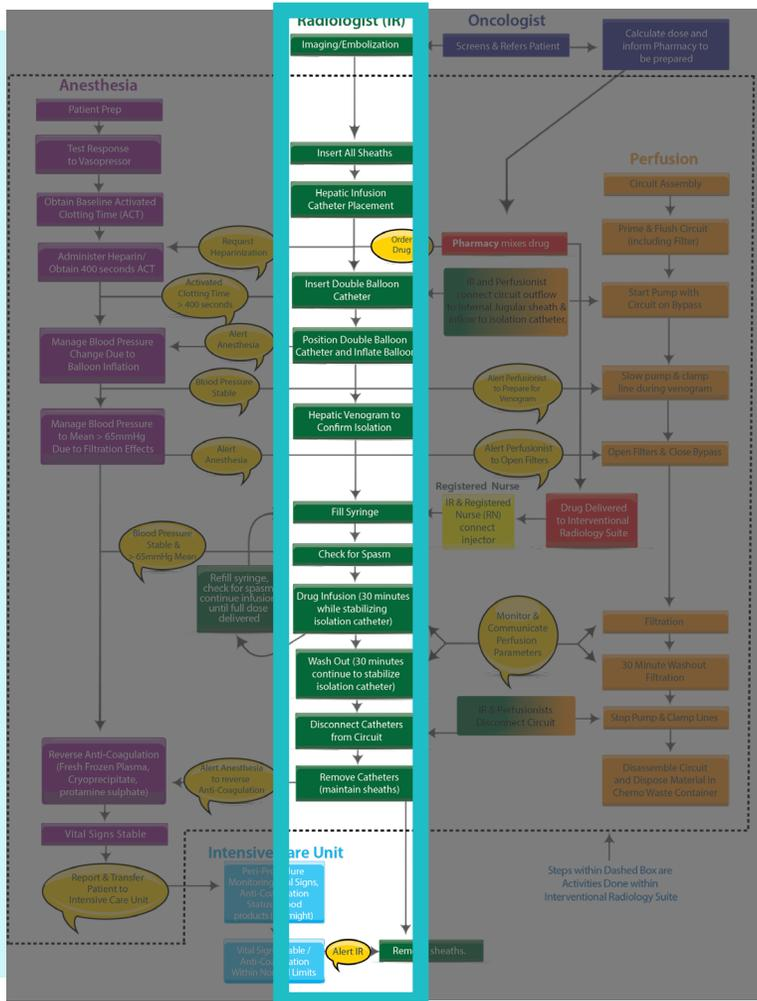

This module describes the steps the Interventional Radiologist takes during the procedure.



- Imaging/Embolization
- Insert All Sheaths
- Insert Double Balloon Catheter
- Hepatic Infusion Catheter Placement
- Position Double Balloon Catheter
- Hepatic Venogram to Confirm Isolation
- Fill Syringe
- Check for Spasm
- Drug Infusion (30 minutes continue to stabilize isolation catheter)
- Wash out (30 minutes continue to stabilize isolation catheter)
- Disconnect Catheters from Circuit
- Remove Catheters (maintain sheaths)



Interventional Radiologist Responsibilities



Interventional
Radiologist

The Interventional Radiologist is the lead physician during the PHP Procedure with HEPZATO KIT and has the following responsibilities:

- Arterial Mapping
- Introducer Placement
- Catheter Positioning
 - *The liver blood supply needs to be assessed in order to formulate a strategy for catheter placement.*
 - *This helps to ensure adequate drug infusion to the entire liver.*
 - *Dependent on vascular anatomy, this may require repositioning of the catheter during the procedure*
- Spasm Management
- Contrast administration during drug infusion

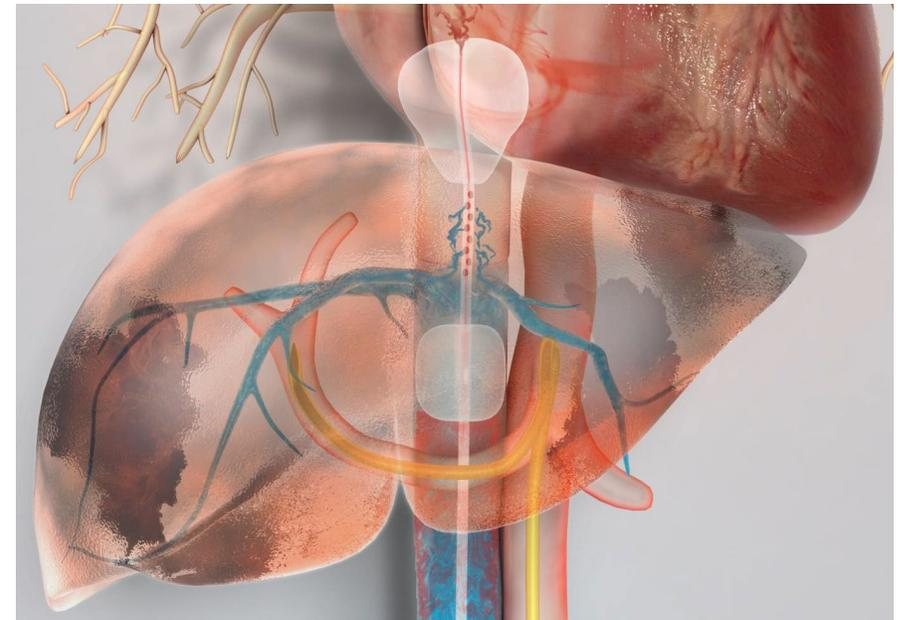



PHP Procedure Eligibility Evaluation



Interventional Radiologist

In order to determine eligibility for each patient, the IR evaluates the following:

Prior surgeries that could potentially affect normal hepatic biliary and vascular anatomy

Reimplanted anatomy; such as the common bile duct which can increase risk of biliary tree infection

The arterial anatomy is assessed during the mapping process and can consist of a superior mesenteric artery angiogram and a celiac angiogram

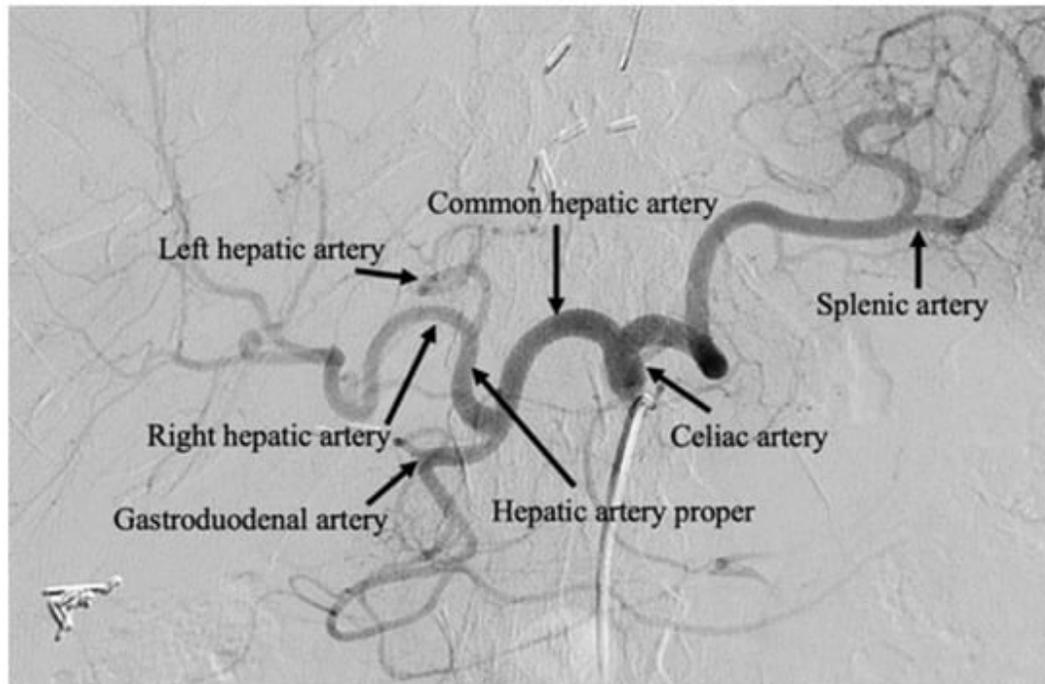

Superior Mesenteric Artery Angiogram



Celiac Angiogram

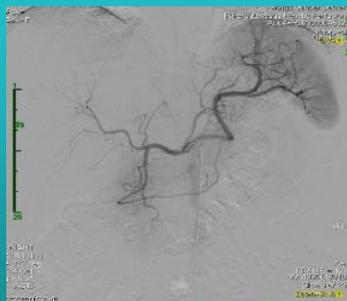

Angiographic evaluation decreases the risk of infusion failure and reflux of melphalan



IR Procedural Awareness



Interventional
Radiologist

Before the PHP procedure the IR should confirm the following:



- KIT Type Decision
(*balloon spacing 50mm or 62mm*)
- Confirm KIT is in the IR Suite
- HEPZATO ordered from the pharmacy
- The patient's most recent lab results
- The treatment start time
- The PHP Procedure team is present



During the PHP procedure the IR must:

- Lead a PHP Procedure team brief
- Ensure that the Anesthesia team is prepared, and that required medications are at hand
- Confirm that hemofiltration circuit is set up by the Perfusionist
 - Confirm HEPZATO arrival time



Selection of Balloon Spacing



Interventional Radiologist

The HEPZATO KIT comes available with two different lengths of balloon spacing: **50mm and 62mm**

Variables that affect the choice of balloon spacing length:

Variation in the **length** of the retro-hepatic segment of the inferior vena cava

Relative **positions** of hepatic and renal veins

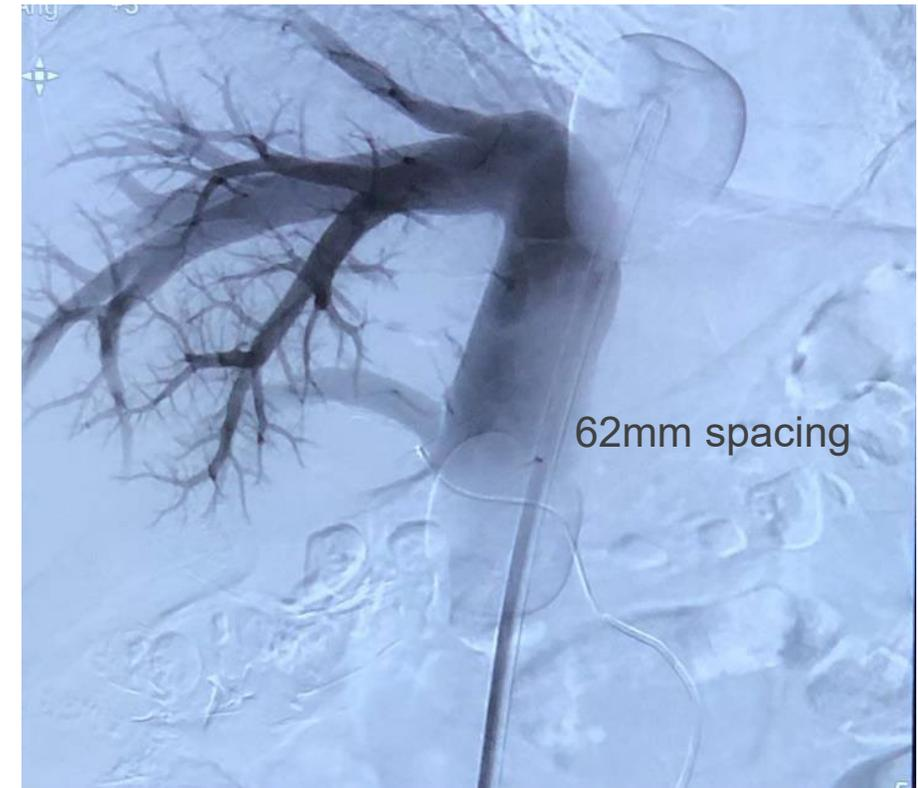

IMPORTANT:

IR needs to decide which KIT (50mm or 62mm spacing) will be used for the PHP procedure **before** the actual PHP procedure



IR Procedural Flow

Insert 10F Introducer Set

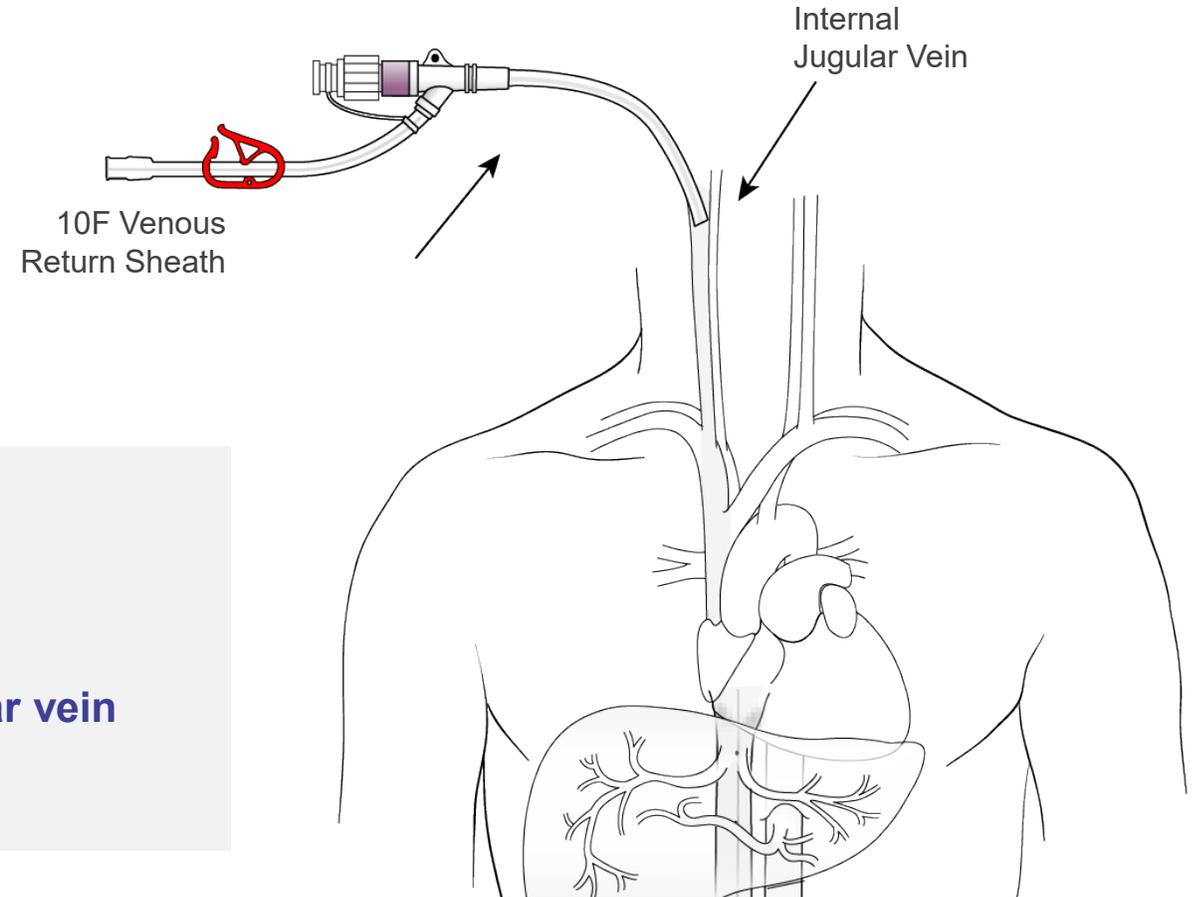
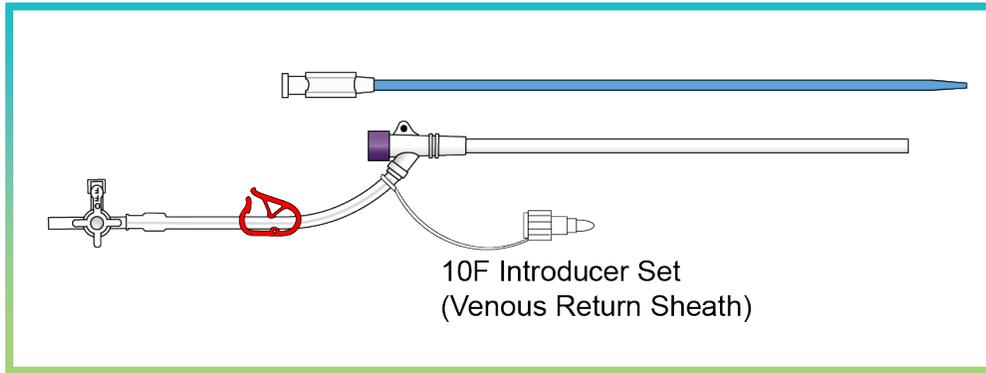

Flush sheath with sterile heparinized saline



Insert venous return sheath into internal jugular vein



IR Procedural Flow

Insert 18F Venous Sheath

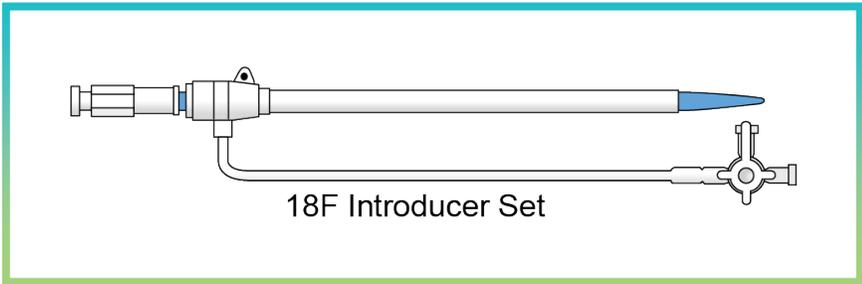
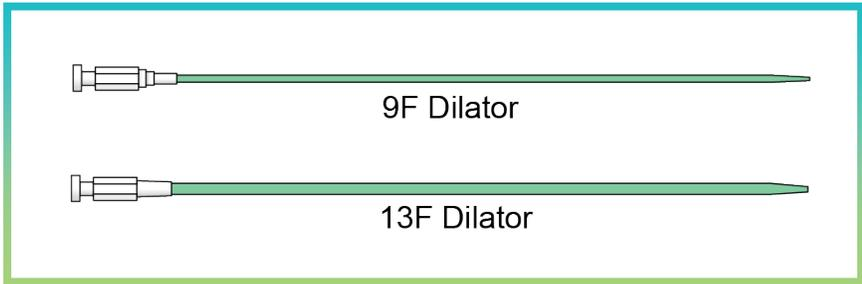

Perform serial dilation with dilators
Insert 18F femoral sheath

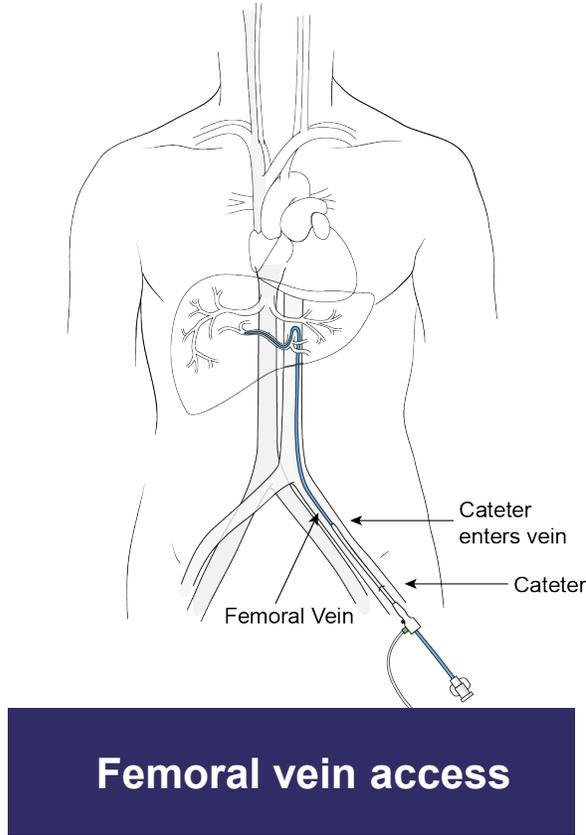
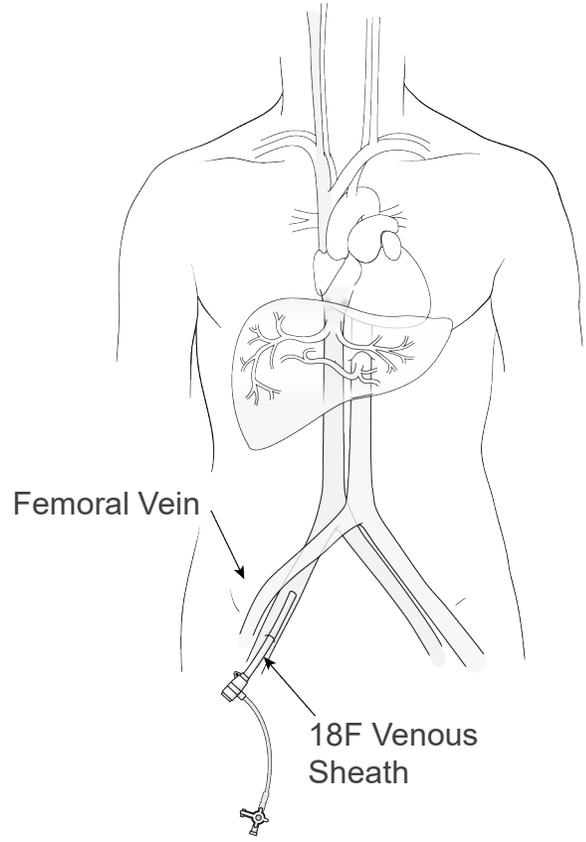

Femoral vein access



IR Procedural Flow

Insert 5F Introducer Set

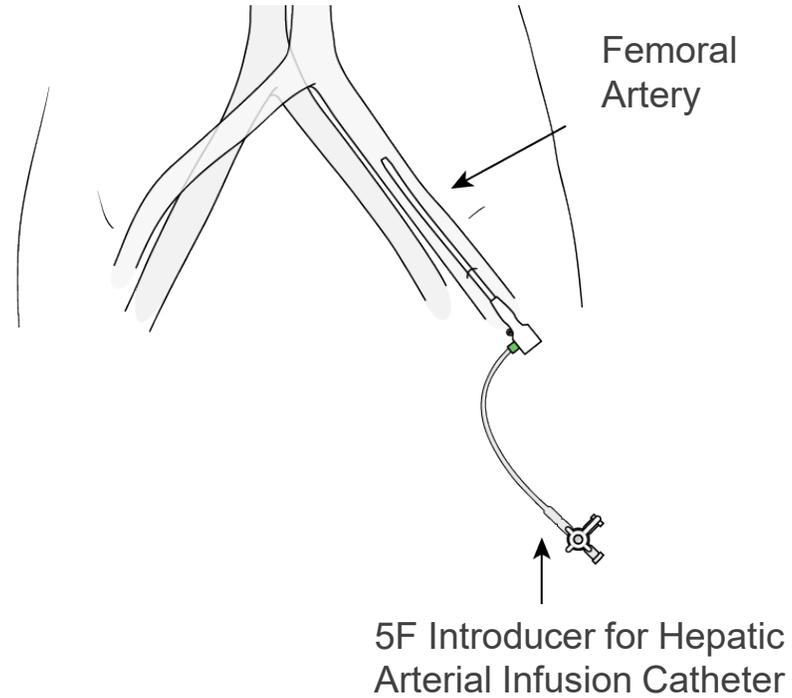
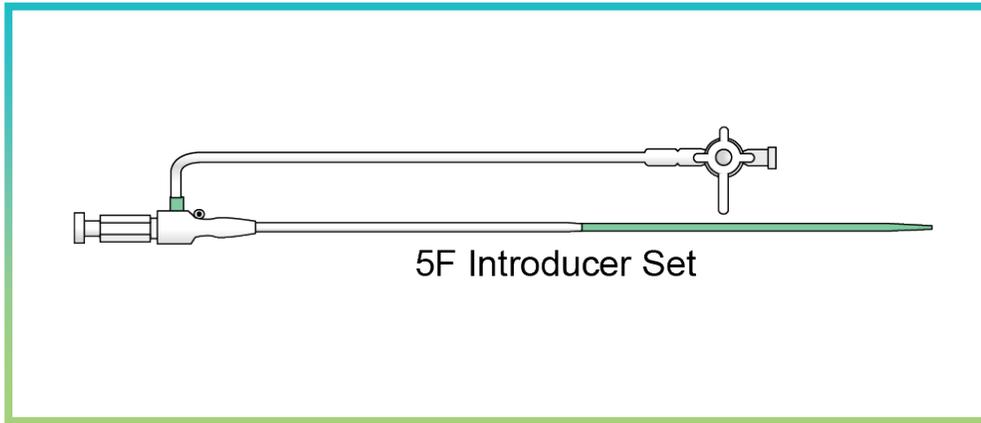

Flush 5F sheath



Place 5F sheath into the femoral artery



Interventional Radiologist:

“Can heparin be administered?”



IR Procedural Flow

Hepatic Vascular Mapping



Interventional
Radiologist

Map Hepatic Artery Anatomy

The Interventional Radiologist needs to create an infusion plan based on hepatic artery mapping.

The infusion plan ensures that all hepatic arteries are adequately perfused.



Embolize As Needed

A selective infusion strategy may be used when the catheter is positioned distal to non-hepatic arterial branches.





IR Procedural Flow

Insert Hepatic Artery Infusion Catheter



Interventional Radiologist

Place Hepatic Artery Catheter

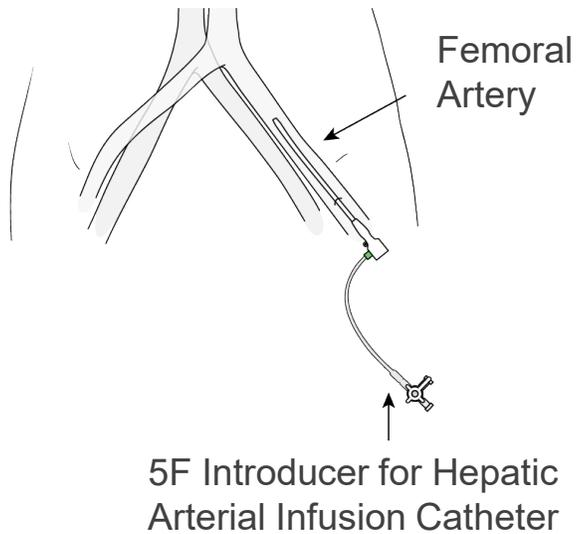

The 5F infusion catheter is introduced through the 5F introducer sheath into the femoral artery.

The infusion catheter and microcatheter is placed in the desired position for HEPZATO infusion.



Interventional Radiologist:

“The catheter has been placed.”



IR Procedural Flow

Catheter Location

Based on evaluation of hepatic artery, two different infusion strategies can be utilized:
Lobar Infusion or Whole Liver Infusion.

If performing a *lobar infusion* approach:

- The catheter is positioned to isolate a lobe
- The treatment is administered sequentially
- It requires HEPZATO dose splitting
- Dosing to each lobe is based on relative liver volume and is traditionally a 60% (right lobe) to 40% (left lobe) split.
- The catheter must be repositioned during HEPZATO infusion
- It is suggested to begin with the most difficult catheterization point in order to minimize catheter repositioning time

If performing a *whole liver* infusion approach:

- Performing a whole liver infusion approach is dependent on arterial blood flow
- Whole liver infusion may require minimal embolization.

Distal catheter placement to non-hepatic arterial branches can reduce requirements for embolization.
Adequate catheter positioning minimizes risk of infusion failure and reflux.



Interventional Radiologist

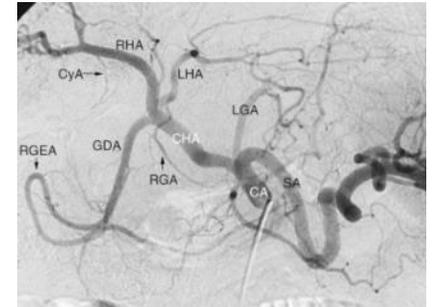

Embolotherapeutic Strategies for Hepatocellular Carcinoma: 2020 Update, Kishore et al, Cancers

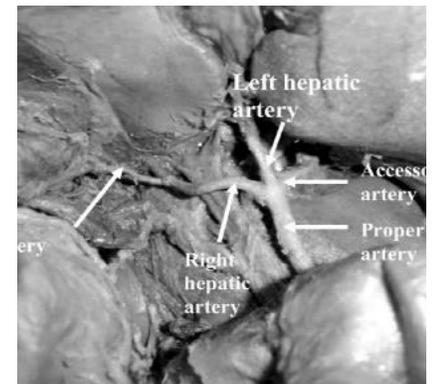

Variant anatomy of the hepatic artery in adult Kenyans, European Journal of Anatomy, 2007, Kitungu et al.



IR Procedural Flow

Insert Double Balloon Catheter (DBC)



In preparation of the placement of the DBC:

HEPZATO should be in the room

The ACT must be above 400 seconds

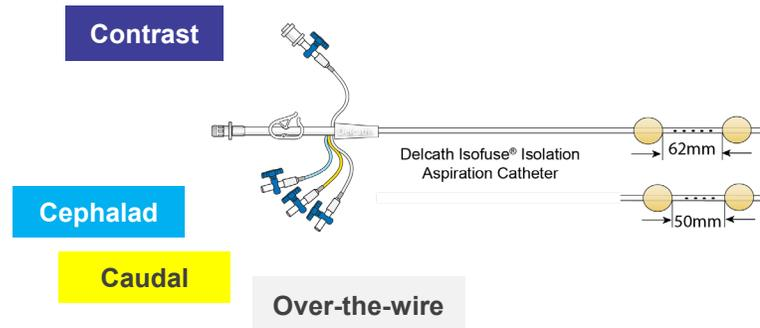
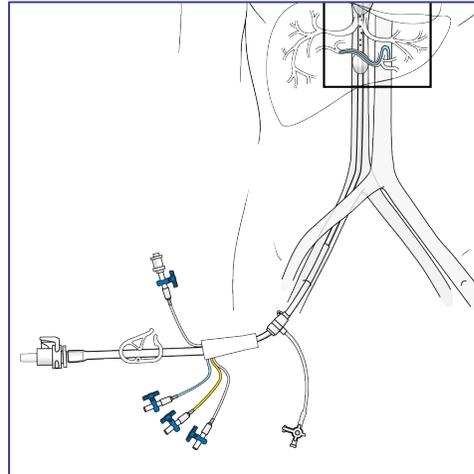

Interventional Radiologist



Interventional Radiologist:

“The DBC has been placed”

Placement of the DBC:

- The DBC catheter should be flushed with heparinized saline via the contrast port and over-the-wire port and central lumen via the extracorporeal system.
- The DBC catheter is inserted through 18F sheath.



IR Procedural Flow

Catheter & Hemofiltration Connection



Interventional Radiologist

To connect the double balloon catheter to the circuit:

- The sterile wrap needs to be removed from the hemofiltration circuit DBC line.
- A wet connection can be made from the hemofiltration DBC line to the DBC catheter by opening saline clamps 1 and 2 and clamp 3.

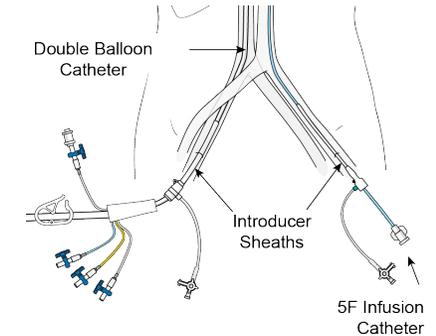
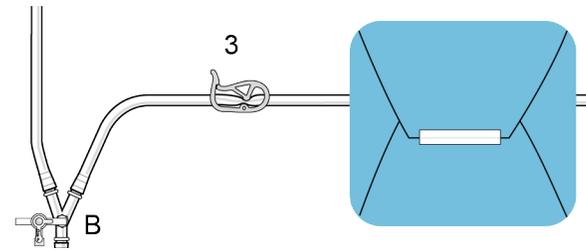

To connect the venous return line to the circuit:

- The sterile wrap is removed from the hemofiltration venous return line.
- The hemofiltration circuit is connected to the venous return line to the stopcock of the 10F venous return sheath in the jugular vein.

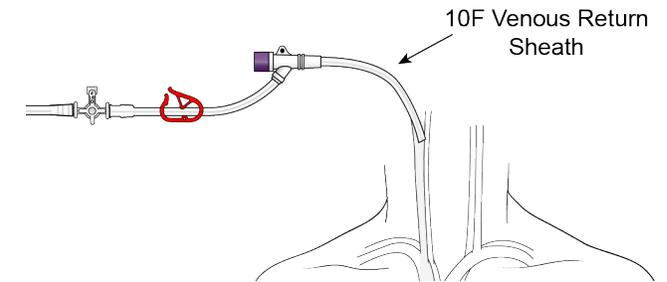
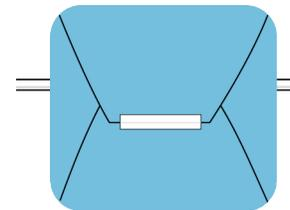



IR Procedural Flow

Establishing Hemofiltration & Isolation



Interventional Radiologist

Start ECF Bypass Circuit

When HEPZATO has been delivered to the procedural room and the connection of the hemofiltration circuit to catheters has been made, the perfusionist turns on the pump and then bypass can be started.

BYPASS:

- ✓ Venous blood aspirated from central lumen
- ✓ Blood flows through fenestrations in DBC
- ✓ Blood flows through the pump
- ✓ Blood flows through the bypass line
- ✓ Blood returns to the patient through the venous return sheath

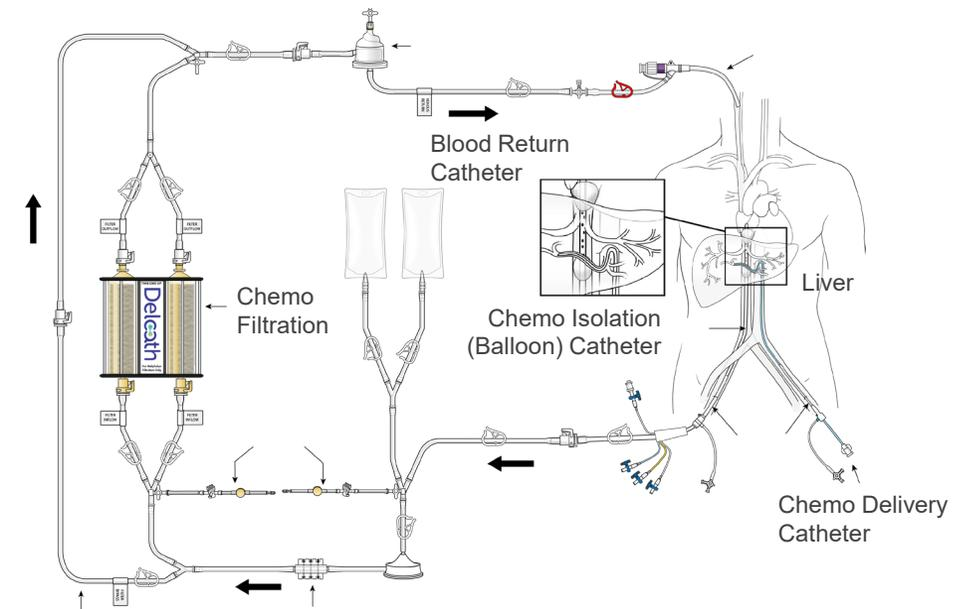

During Hemofiltration and Isolation, the Perfusionist continuously monitors the pump pressures



Vasopressor Administration



Anesthesiologist



Interventional Radiologist



Prior to occlusion of vena cava and inflation of balloons a vasopressor response test is performed by the Anesthesiologist.



Initial occlusion of the inferior vena cava leads to a significant decrease of systemic blood pressure. It is of critical importance to maintain the blood pressure above 65 mmHg.



If response to vasopressors is adequate, the double balloon catheter may be inflated.



IR Procedural Flow

Balloon Expansion



Interventional Radiologist

The balloon is expanded until the lateral edges become effaced with the inferior vena cava wall.

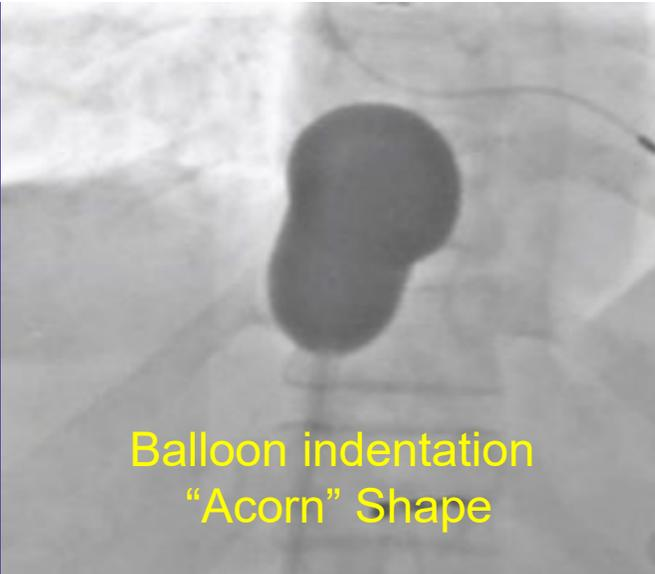

The **cephalad** balloon must occlude inferior vena cava just *above* the *highest* hepatic vein

The **caudal** balloon must occlude inferior vena cava just *below* the *lowest* hepatic vein

Never move or reposition the DBC when the balloons are fully expanded.

DO NOT collapse balloons unless HEPZATO administration has been stopped or after completion of infusion, including a 30-minute washout cycle.

The Perfusionist must carefully monitor the circuit flow rate during balloon inflation.



IR Procedural Flow

Hepatic Venous Isolation Confirmation & Leak Assessment



Interventional Radiologist

Iodinated contrast medium is injected through the contrast port to assess isolation of the segment.

To check for balloon leaks:

- 1 The Perfusionist stops the pump.
- 2 The IR checks for leaks by injected contrast agent through the DBC
- 3 If no leak is seen, the Perfusionist starts the pump again.



Hemofiltration Circuit Flow is re-established by:

- 1 Restarting the centrifugal pump
- 2 Increasing pump speed to approximately 2200 RPMs or the previously established flow rate

If the **DBC** is not in the proper position, collapse both balloons (caudal balloon first) and then reposition the catheter, while maintaining flow in the hemofiltration circuit



IR Procedural Flow

Balloon Occlusion



Interventional Radiologist

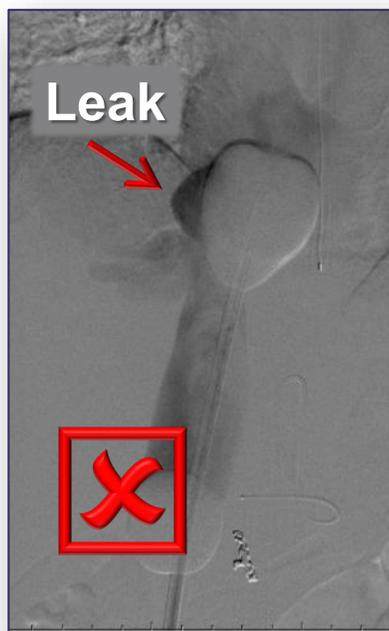
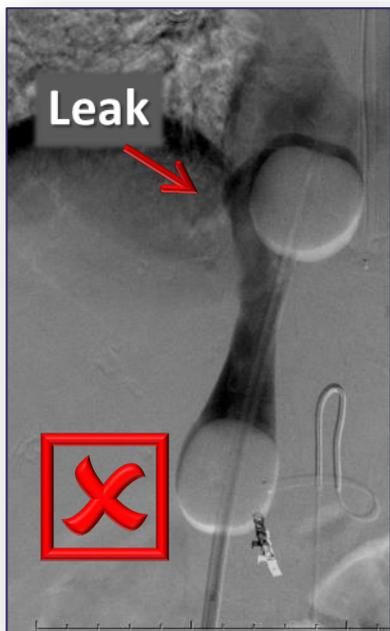

Correctly Occluded

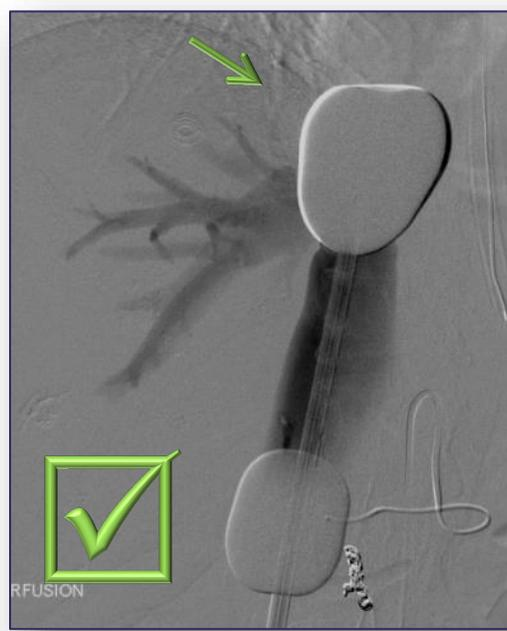

Balloon Inflation Volumes

Balloon	Cephalad	Caudal
Maximum Volume	38 mL	38 mL

- Under fluoroscopy, the balloons are partially inflated with approximately 15-25 mL of dilute contrast media.
- Inflation of the balloons may give it a rounded appearance.

The balloons must not be over inflated. Overinflation could cause the balloons to burst and result in life-threatening injury.



Opening Filters & Blood Pressure Management

The Process for Turning on the Filters



Interventional Radiologist

The flow is checked by the IR.

The IR instructs the Perfusionist to turn the filters on; usually one filter at a time.

The bypass line is kept open as each filter is opened.

After both filters are filled with blood, the bypass line is closed after 3 minutes of flow.

The blood pressure is monitored for 2 to 5 minutes.



Interventional Radiologist



Interventional Radiologist

*“Turn filter 1 on
Turn filter 2 on
Close bypass lines”*



Perfusionist



Perfusionist

“Bypass lines are closed”



Anesthesiologist



Anesthesiologist

*“Blood pressure is...
MAP is...”*



IR Procedural Flow - Hepatic Artery Spasm



Once the blood pressure is stabilized the IR **injects contrast agent** to check for hepatic artery spasm.

IF SPASM IS OBSERVED:

POSSIBLE CAUSE	>	vasopressor therapy & low mean arterial pressure
EFFECT	>	reflux of melphalan into proximal non-embolized gastrointestinal branches or incomplete delivery of HEPZATO
DURING PROCEDURE	>	perform Angiography every 5 minutes
SPASM RELIEF	>	100 mcg/injection of intra-arterial nitroglycerin in hepatic artery

If there is a persistent intractable spasm, the procedure should be stopped.



IR Procedural Flow

Infusion, Filtration & Double Balloon Catheter (DBC) Management



Once the IR approves the start of HEPZATO infusion a 100 mL bolus is administered at 25 mL/second flow rate using drug injector. (estimated 4 min infusion time).
The IR maintains a gentle hold of the DBC position during the entire infusion period.
HEPZATO is refilled into the drug injector and the IR performs a spasm check.



First 30 minutes:
HEPZATO Infusion

Last 30 minutes:
Washout period

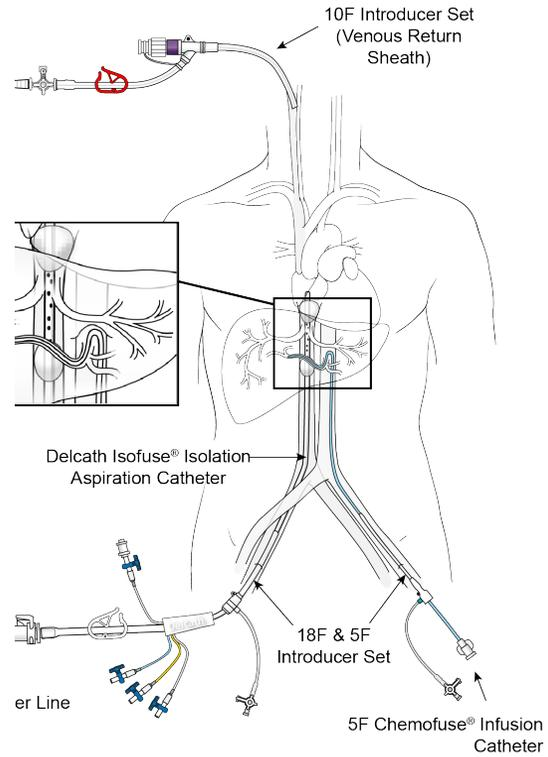

The DBC position checked fluoroscopically every 4 to 5 minutes during drug administration and filtration to ensure continued hepatic venous isolation



IR Procedural Flow

Procedure End



Interventional Radiologist

The IR may return blood to the patient at the end of the washout period. Blood return may be dependent on central venous pressure and the amount of fluid given.

To return blood to the patient the IR instructs the Perfusionist to open clamps for saline flush and this flush pushes the blood through the filter and back into patient's internal jugular vein.

At the end of blood return the Perfusionist properly disposes all the hemofiltration lines, pump, and the filters.

The Anesthesia team starts post procedural medications.



Anesthesiologist

MODULE 8

Anesthesia, Anticoagulation and Hemodynamic Management



Module 8 Objectives

Module 8 describes the responsibilities of the anesthesiologist/anesthetist on the day of the procedure.

This includes medically clearing the patient for the PHP Procedure with HEPZATO KIT, managing preoperative medications, managing anesthesia, blood oxygenation, acid/base balance, core body temperature, hydration, anticoagulation, and blood pressure. Patient to be assessed for adequate cardiopulmonary function.

**Managing
preoperative
medications.**

**Managing
hydration
optimizing blood
pressure and
EFC flow rate.**

**Managing
anticoagulation.**

**Managing blood
pressure.**



Anesthesiologist Procedural Tasks



Anesthesiologist

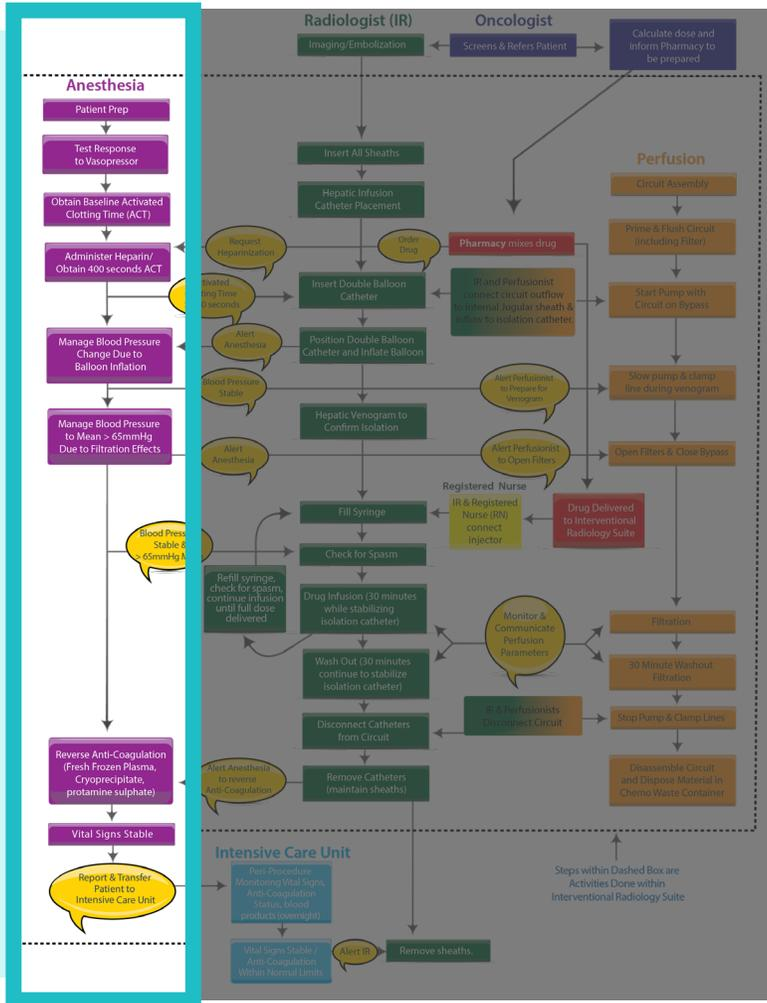

This module describes the steps that the Anesthesiologist takes during the procedure.



- Patient Prep
- Test Response to Vasopressor
- Obtain Baseline Activated Clotting Time (ACT)
- Administer Heparin/Obtain 400 seconds ACT
- Manage Blood Pressure Change Due to Balloon Inflation
- Manage Blood Pressure to Mean > 65 mmHG Due to Filtration Effects
- Reverse Anti-Coagulation (Fresh Frozen Plasma, Cryoprecipitate, protamine sulphate)
- Vital Signs Stable



HEPZATO KIT Preoperative Patient Assessment



Anesthesiologist

After referral by the Medical Oncologist, a preoperative assessment of the patient is performed by the Anesthesiologist, the Cardiologist, and the Pulmonologist.

Each HCP must adjudicate pre-operative clearance indicating adequate cardiac and pulmonary function.

A patient may not be eligible for HEPZATO KIT treatment if any of the following are present:

- Active coronary artery disease
- Severe angina
- Recent myocardial infarction
- Any congestive heart failure
- Significant ventricular arrhythmias
- Moderate to severe valvular disease
- Unable to withstand high dose vasopressor therapy
- Advanced COPD
- Unable to withstand mechanical ventilation





Procedure

Anesthesia Team



Anesthesiologist

Anesthesia Induction

- A Bair hugger can be used to keep the patient warm.
- The Anesthesiology team may use an endotracheal tube or a laryngeal mask to induce anesthesia.



Bair Hugger

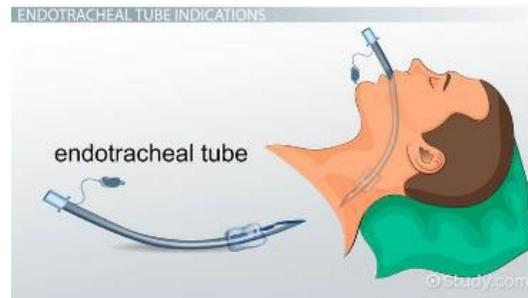

Endotracheal tube

OR

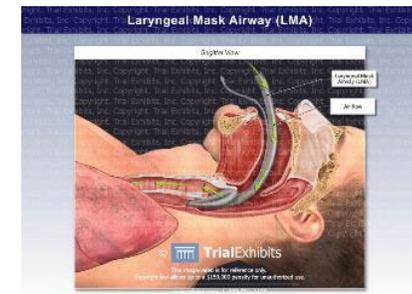

Laryngeal mask



Procedure

Anesthesia Team



Anesthesiologist



To optimize the fluid balance, boluses of fluids such as saline and crystalloids are administered via the central venous catheter during anesthesia induction and line insertion.



The variation of the pump flow informs of fluid responsiveness.



Vasopressors such as norepinephrine and epinephrine are administered to manage drops in blood pressure.



Anticoagulation



Interventional Radiologist

Interventional Radiologist:

“What is the ACT?”

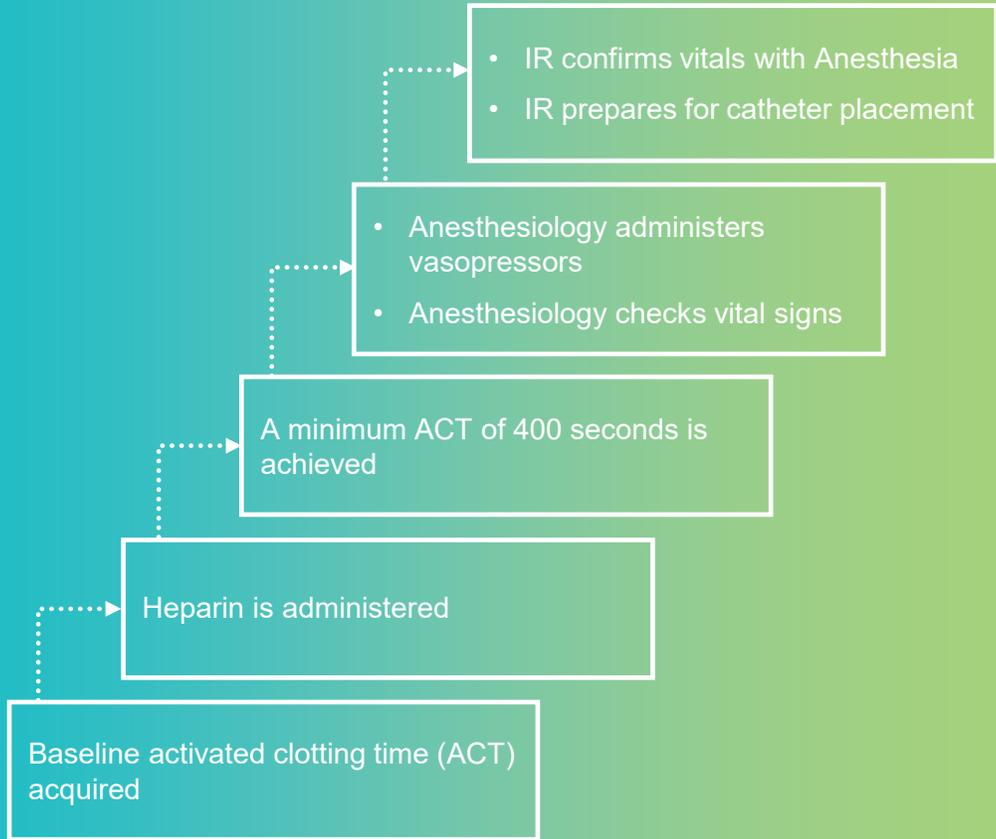

Anesthesiologist

Anesthesiologist:

“Vasopressors have been administered”



PHP Procedure

Anesthesiologist Role



Anesthesiologist



Anesthesiologist

OR



Perfusionist

- The Anesthesiologist or the Perfusionist obtains the baseline ACT



Anesthesiologist

>



Interventional Radiologist

- The Anesthesiologist administers Heparin
- The Anesthesiologist administers vasopressors to maintain blood pressure *before* DBC placement by the IR

Anticoagulation is required to assure free extracorporeal flow and filtration



PHP Procedure – Anesthesia Responsibilities

Anesthesia Responsibilities

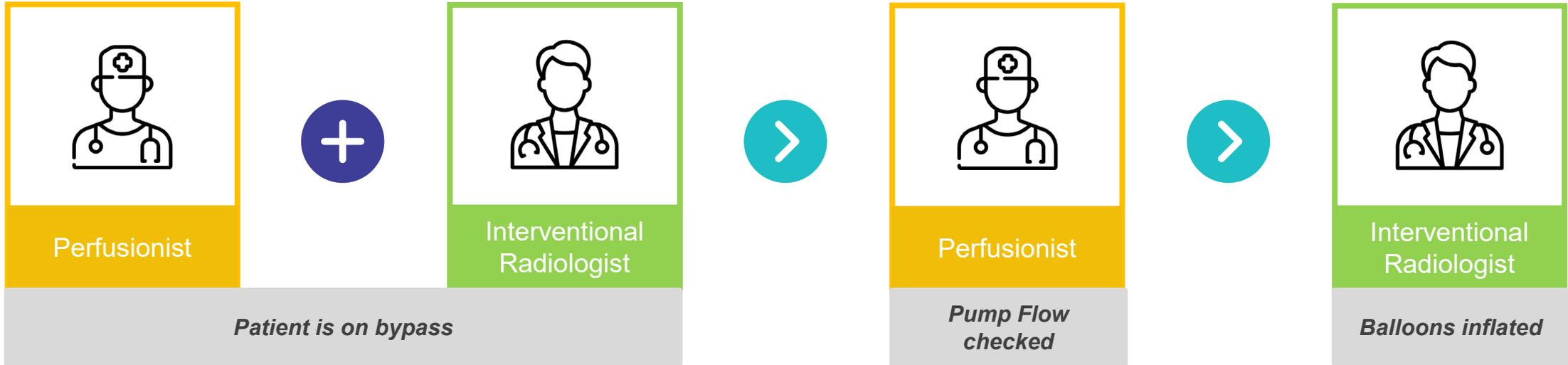

Anesthesiologist

The Anesthesiologist:

Monitors the blood pressure

Administers vasopressors

Stabilizes the mean arterial pressure



PHP Procedure

Anesthesia Responsibilities



Anesthesiologist



Perfusionist

Filters brought online



Anesthesiologist stabilizes the MAP



Anesthesiologist



Perfusionist

Extracorporeal circulation filtration stopped



Anesthesiologist discontinues vasopressors



Anesthesiologist



PHP Procedure

Post Procedure



Anesthesiologist



Anesthesiologist

Discontinues heparin

Weans off vasopressors

Administers fluids

Extubates the patient

Initiates recovery

Removes endotracheal tube or laryngeal mask

Removes arterial catheter and closure device

May leave femoral venous sheath and jugular sheath in position

Optional | Give fresh frozen plasma (FFP) and thrombocytes



Anesthesiologist

MODULE 9

Post-Procedure Management & Discharge



Module 9 Objectives

Module 9 describes the responsibilities of the intensivist to recover the patient after the procedure. This includes reversing anticoagulation, removing intravascular introducers (sheaths), normalizing hematologic abnormalities (e.g., anemia and thrombocytopenia), and normalizing procedural abnormalities (e.g., metabolic acidosis and hypothermia).



Mechanisms reversing anticoagulation and safe removal of vascular sheaths.



Correcting hematologic abnormalities.



Correcting metabolic acidosis and hypothermia

NOTE:

Patients should be assessed for severe peri-procedural complications associated with HEPZATO KIT for at least 72 hours after the procedure.

Severe peri-procedural complications should be documented and submitted to the REMS using the Severe Peri-Procedure-related Complications Adverse Events Documentation Form.

Follow up may occur virtually or via telephone for patients discharged prior to 72 hours.



Post Procedural Recommendations

Prior to discharge after the PHP Procedure with HEPZATO, it is recommended that the following procedure-related events are corrected:

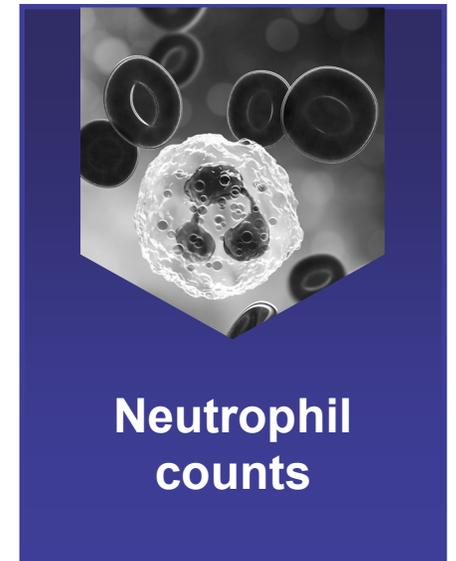
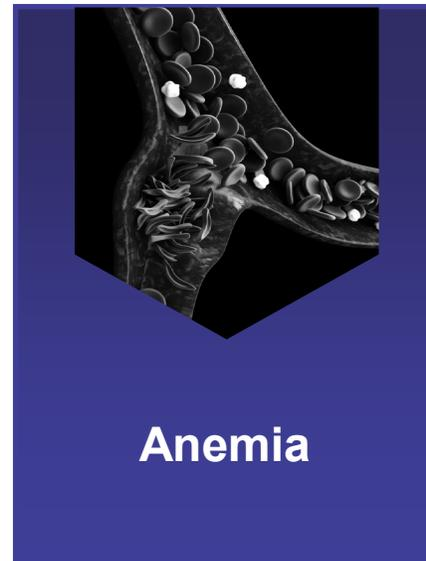
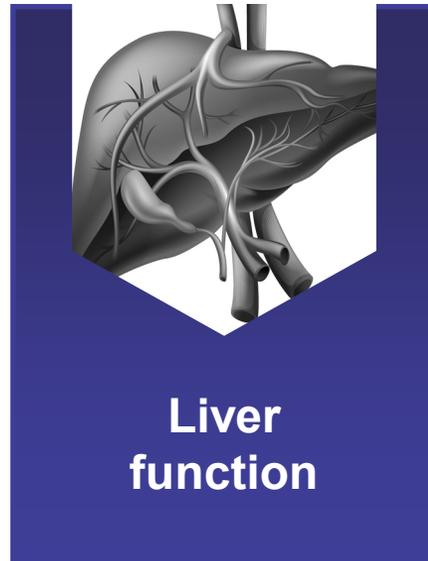
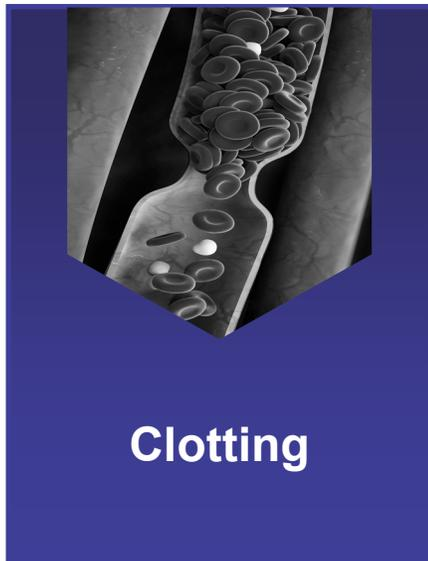

Corrections of post-procedure events should follow institutional guidelines and clinical judgment.



End of Procedure

Anticoagulation Interventions & Hematologic Abnormalities

To reverse anticoagulation and attend to procedural induced coagulopathies

Protamine is titrated to normalize the Activated Clotting Time (ACT).

Clotting factors may be replenished by administration of cryoprecipitate and/or Fresh Frozen Plasma.

To correct hematologic abnormalities

Platelets should be replaced according to institutional guidelines.

Ensure that the platelet count is greater than 50,000/mm³ and patient coagulation status is normalized before safely removing sheaths.

Blood product replacement should be considered if patient has significant blood loss. It is suggested to follow institutional guidelines for administration of packed red blood cells, follow anemia hospital protocols, and transfuse accordingly.



Patient Discharge & Follow Up



Discharge

Prior to discharge, physiologic abnormalities should be reviewed and reversed.



Medical Oncologist Responsibilities

Follow up with the patient after hospital discharge.

Clear the patient for subsequent treatment.

Evaluate need for dose adjustment or treatment discontinuation.

Administer prophylactic treatment to manage hematologic toxicities.

Monitor patient on an outpatient basis after hospital discharge for HEPZATO related toxicities